

OPERATOR'S MANUAL

Model 95

20 MHz Synthesized
ARB/Function Generator

© 1990 Wavetek

This document contains information proprietary to Wavetek and is provided solely for instrument operation and maintenance. The information in this document may not be duplicated in any manner without the prior approval in writing from Wavetek.

WAVETEK

WAVETEK SAN DIEGO, INC.
9045 Balboa Ave., San Diego, CA 92123
P. O. Box 85265, San Diego, CA 92138
Tel 619/279-2200 TWX 910/335-2007

Manual Revision: 7/90
Version: Operator's
Manual Part Number:

WARRANTY

Wavetek warrants that all products manufactured by Wavetek conform to published Wavetek specifications and are free from defects in materials and workmanship for a period of one (1) year from the date of delivery when used under normal operating conditions and within the service conditions for which they were furnished.

The obligation of Wavetek arising from a Warranty claim shall be limited to repairing, or at its option, replacing without charge, any product which in Wavetek's sole opinion proves to be defective within the scope of the Warranty. In the event Wavetek is not able to modify, repair or replace non-conforming defective parts or components to a condition as warranted within a reasonable time after receipt thereof, Buyers shall be credited for their value at the original purchase price.

Wavetek must be notified in writing of the defect or nonconformity within the Warranty period and the affected product returned to Wavetek's factory or to an authorized service center within thirty (30) day after discovery of such defect or nonconformity.

For product warranties requiring return to Wavetek, products must be returned to a service facility designated by Wavetek. Buyer shall prepay shipping charges, taxes, duties and insurance for products returned to Wavetek for warranty service. Except for products returned to Buyer from another country, Wavetek shall pay for return of products to Buyer.

Wavetek shall have no responsibility hereunder for any defect or damage caused by improper storage, improper installation, unauthorized modification, misuse, neglect, inadequate maintenance, accident or for any product which has been repaired or altered by anyone other than Wavetek or its authorized representative and not in accordance with instructions furnished by Wavetek.

Exclusion of Other Warranties

The Warranty described above is Buyer's sole and exclusive remedy and no other warranty, whether written or oral, is expressed or implied. Wavetek specifically disclaims the implied warranties of merchantability and fitness for a particular purpose. No statement, representation, agreement, or understanding, oral or written, made by an agent, distributor, representative, or employee of Wavetek, which is not contained in the foregoing Warranty will be binding upon Wavetek, unless made in writing and executed by an authorized Wavetek employee. Under no circumstances shall Wavetek be liable for any direct, indirect, special, incidental, or consequential damages, expenses, losses or delays (including loss of profits) based on contract, tort, or any other legal theory.

Contents

SECTION 1 GENERAL

1.1 About this manual.....	1-1
1.2 Model 95	1-1
1.3 Specifications	1-1
1.3.1 Waveforms (Functions).....	1-1
1.3.2 Operational Modes.....	1-2
1.3.3 Frequency.....	1-3
1.3.4 Amplitude.....	1-4
1.3.5 Offset.....	1-4
1.3.6 Outputs.....	1-5
1.3.7 Inputs.....	1-5
1.3.8 Display.....	1-6
1.3.9 GPIB Programming.....	1-6
1.3.10 Arbitrary Waveform Generator.....	1-6
1.4 Options	1-7
1.5 General	1-7

SECTION 2 PREPARATION

2.1 RECEIVING AND INSPECTING SHIPMENTS.....	2-1
2.2 RETURNING EQUIPMENT FOR REPAIR	2-1
2.3 PREPARATION FOR STORAGE OR SHIPMENT	2-1
2.3.1 Packaging	2-1
2.3.2 Storage	2-2
2.4 PREPARATION FOR USE.....	2-2
2.4.1 Power and Fuse Selection.....	2-2
2.4.2 Installation	2-3
2.4.3 Initial Turn-on	2-3
2.4.4 AutoCal and Calibrate	2-5
2.4.5 Maintenance Messages and Error Codes	2-5
2.5 FUNCTIONAL CHECKOUT.....	2-5

SECTION 3 OPERATION

3.1 INTRODUCTION	3-1
3.2 CONTROLS, CONNECTOR, AND INDICATORS	3-1
3.2.1 Front Panel Controls, Indicators, and Connectors.....	3-1
3.2.2 Rear Panel Connectors.....	3-18
3.3 GPIB (Remote) Operation	3-20
3.4 GPIB COMMAND STRUCTURE.....	3-22
3.4.1 Introduction	3-22
3.4.2 Model 95 Commands.....	3-22
3.4.2.1 Command Types.....	3-23
Parameter Commands.....	3-23
Enumerated Commands	3-23
Direct Commands	3-23
Query Commands.....	3-23
3.4.2.2 Model 95 Command Syntax	3-24
Command String Operation.....	3-24
How Does the Model 95 Process Commands?.....	3-24
Terminators.....	3-24
Minimum Uniqueness	3-25
Query Commands.....	3-25

Contents (continued)

3.4.2.3 Model 95 Command List	3-25
3.4.3 Universal and Addressed Commands	3-34
U/A Syntax	3-34
3.4.4 Detailed Command Descriptions	3-34
3.4.5 Service Requests - SRQ	3-36
3.4.6 Displaying Messages	3-38
3.4.7 Selftest Query Responses	3-39
3.5 OPERATION	3-41
3.5.1 Instrument Setup	3-41
3.5.2 Power On and Reset	3-43
Setting a Single Parameter to its Default Value	3-43
Setting all Parameter to their Default Values	3-43
3.5.3 Basic Generator Setup	3-43
3.5.3.1 Local Operation	3-44
3.5.3.2 GPIB Operation	3-46
3.5.4 Variable Symmetry	3-47
3.5.4.1 Local Operation	3-48
3.5.4.2 GPIB Operation	3-48
3.5.5 Phase Lock and Phase Shift	3-48
3.5.5.1 Internal Phase Lock	3-49
3.5.5.2 External Phase Lock	3-49
3.5.5.3 Phase Shift	3-51
3.5.6 Continuous Arbitrary Waveform	3-51
3.5.6.1 Local Operation	3-51
3.5.6.2 GPIB Operation	3-52
3.5.7 Triggered Mode	3-53
3.5.7.1 Internal Trigger	3-53
3.5.7.2 External Trigger	3-54
Local Operation	3-54
Manual Trigger	3-55
GPIB Operation	3-55
Triggering with GPIB Commands	3-56
3.5.8 Gated Mode	3-56
3.5.8.1 Internal Triggered Gate	3-56
Local Operation	3-56
GPIB Operation	3-56
3.5.8.2 External Triggered Gate	3-57
Local Operation	3-57
Manual Trigger	3-58
GPIB Operation	3-58
Gating with GPIB Commands	3-58
3.5.9 Burst Mode	3-58
3.5.9.1 Internally Triggered Bursts	3-58
3.5.9.2 External Triggered Bursts	3-60
3.5.10 Amplitude Modulation	3-61
3.5.10.1 Local Operation	3-62
3.5.10.2 GPIB Operation	3-62
3.5.11 Suppressed Carrier	3-63
3.5.11.1 Local Operation	3-63
3.5.11.2 GPIB Operation	3-63
3.5.12 Frequency Modulation	3-64
3.5.12.1 Local Operation	3-66
3.5.12.2 GPIB Operation	3-66
3.5.13 VCG	3-67
3.5.13.1 Local Operation	3-68
3.5.13.2 GPIB Operation	3-69
3.5.14 Continuous Sweep	3-70



Contents (continued)

3.5.14.1 Local Operation.....	3-70
3.5.14.2 GPIB Operation.....	3-71
3.5.15 Triggered Sweep	3-72
3.5.15.1 Local Operation.....	3-72
3.5.15.2 GPIB Operation.....	3-73
3.5.16 Manual Sweep	3-75
3.5.17 Storing And Recalling Settings	3-76
3.5.17.1 Local Operation	3-76
3.5.17.2 GPIB Operation	3-76
3.5.18 Arbitrary Waveforms	3-78
3.5.18.1 Introduction.....	3-78
3.5.18.2 Arb Keys	3-79
3.5.19 Arb Edit	3-80
3.5.19.1 Arb-Instrument Setup.....	3-81
3.5.19.2 Erasing Arb Waveforms.....	3-81
3.5.19.3 Correcting a Mistake	3-81
3.5.19.4 Point Edit.....	3-81
3.5.19.5 Line Edit – 2 Point.....	3-85
3.5.19.6 Three Point Edit	3-88
3.5.19.7 Block Edit	3-89
3.5.20 Storing Arb Waveforms	3-92
3.5.21 Filter	3-93
3.5.22 Smoothing	3-93
3.5.23 Binary Arb Waveform Transfer	3-94
APPENDIX B Byte Reversing	B-1

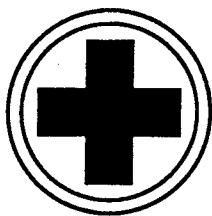
SAFETY FIRST



Protect yourself. Follow these precautions:

- Don't touch the outputs of the instrument or any exposed test wire carrying the output signals. This instrument can generate hazardous voltages and currents
- Don't bypass the power cord's ground lead with two-wire extension cords or plug adapters.
- Don't disconnect the green and yellow safety-earth-ground wire that connects the ground lug of the power receptacle to the chassis ground terminal (marked with  or )
- Don't plug in the power cord until directed to by the installation instructions.
- Don't repair the instrument unless you are a qualified electronics technician and know how to work with hazardous voltages.
- Pay attention to the **WARNING** statements. They point out situations that can cause injury or death.
- Pay attention to the **CAUTION** statements. They point out situations that can cause equipment damage.

WARNING

This instrument normally contains lithium batteries. Where lithium is prohibited, such as aboard U.S. Navy ships, verify that the lithium battery has been removed.

Do not recharge, short circuit, disassemble, or apply heat to the lithium battery. Violating this rule could release potentially harmful lithium. Observe polarity when you replace the battery.

SECTION 1

GENERAL

1.1 ABOUT THIS MANUAL

The Model 95, 20 MHz Synthesized Arbitrary/Function Generator Instruction Manual provides information on how to use and maintain the Model 95.

Section 1, General, lists and describes the Model 95 specifications.

Section 2, Preparation, provides preliminary unit setup instructions. This section includes instrument receiving and inspection, return for repair, initial checkout including fuse and voltage selection and turn on, error messages, and functional check.

Section 3, Operation, describes instrument operation – local (front panel) and remote (GPIB).

1.2 MODEL 95

The Model 95 is a rugged 1mHz to 20 MHz programmable, synthesized Arbitrary/Function Generator. The function generator produces predefined sine, triangle, and square waveforms. While the arbitrary waveform generator (Arb) supplies user-defined waveforms. Function generator and Arb waveforms can be continuous, triggered, gated, burst, AM (amplitude modulation), SCM (suppressed carrier modulation), FM (frequency modulation), or sweep. The two main outputs (balanced and unbalanced) supply the selected waveform at levels from 1mVpp to 30 Vpp

The Arb generator lets the user to define up to four functions (waveforms). The unit stores these waveforms in its battery-backed memory (RAM). Each of the four Arb waveforms may be 2 words to 8K words horizontal by 12 bits (4096 points) vertical; also see Option 002. Edits the Arb waveforms using point, line, or three point edit methods. Plus, the Model 95 can insert dc, triangle, square, ramp up, ramp down, sine, cosine, inverse sine, or inverse cosine within a waveform.

At frequencies above 20Hz (all functions in continuous, AM, and SCM modes) the Model 95 phase locks its function generator to its own internal frequency synthesizer (internal phase lock). The internal synthesizer improves the frequency accuracy to $\pm(10\text{ppm} + 1.5\text{ppm}/^\circ\text{C})$; also see Option 001. This internal frequency synthesizer also acts as an internal trigger source for the trigger, gate, or burst modes. Also the Model 95 can phase lock to an external source (same conditions as internal phase lock). When external phase locked, the Model 95 allows the phase of the output to be shifted $\pm 180^\circ$.

1.3 SPECIFICATIONS

1.3.1 Waveforms (Functions)

Programmable sine, triangle, and square; variable symmetry for pulse and ramp waveforms; arbitrary waveforms; and dc.

Sine Distortion

Sine function at all outputs :

- <1% (-40dB) THD 1mHz to 20Hz;
- <0.5% (-46dB) THD 20Hz to 100 kHz.

Arb Sine Waveform, ≥ 100 points, 50 kHz filter:

- <0.18% (-55dB) THD to 100 kHz.

Unbalanced Output, 50 Ω and 75 Ω , no harmonics above:

-40dBc, 100 kHz to 2MHz,

-30dBc, 2MHz to 6MHz,

-25dBc, 6MHz to 20 MHz.

Time Symmetry

With fixed 50% time symmetry the accuracy is $\leq \pm(0.2\% + 5 \text{ ns})$. Time symmetry is variable from 5% to 95% in 1% steps to 2 MHz. Between 2MHz and 20 MHz the time symmetry limits linearly decrease to a fixed 50% at 20 MHz. Accuracy is $\leq \pm(1\% + 5 \text{ ns})$.

Square Transition Time

The transition time (rise/fall) is $< 9 \text{ ns}$, 10% to 90%, unbalanced output into 50 Ω impedance.

Aberrations

Overshoot and ringing is $< (5\% + 20 \text{ mV})$ of the peak to peak amplitude.

Triangle Linearity

10% to 90% nonlinearity:

$\pm 1\%$, 2mHz to 100 kHz;

$\pm 2\%$, 100 kHz to 2MHz;

$\pm 10\%$, 2MHz to 5MHz.

1.3.2 Operational Modes

Continuous

In this mode, the Model 95 supplies a continuous waveform at the selected frequency. The unit automatically selects its internal synthesizer at frequencies above 20Hz.

Triggered

In this mode, the Model 95 remains quiescent at trigger baseline of selected function until a trigger event occurs. The Trig/Freq In signal, Manual Trigger, GPIB trigger command, or internal trigger starts the trigger event. This event initiates a single waveform at the programmed frequency and, after completing the waveform, returns the generator to the quiescent baseline. Accuracy of triggered waveform period is $< \pm 3\%$.

Gated

In this mode the Model 95 functions the same as the Triggered mode, except the generator runs continuously while the trigger event is true. The generator starts and stops in the quiescent state, and the Model 95 always completes its last cycle. Gate outputs initiated by the internal synthesizer have an approximate 1:1 on/off cycle.

Burst

In this mode, the Model 95 functions like the Triggered mode, except that the number of cycles generated, when triggered, is programmable from 1 to 1,000,000. The generator starts and stops in its quiescent state.

Amplitude Modulation (AM)

In this mode the Model 95 functions like the continuous mode except an external signal modulates the amplitude of the Model 95's output (carrier). The external signal can modulate the Model 95 from 0 to 100%. In this mode, the Model 95 displays the average amplitude; the Continuous amplitude must be $<7.5V_{pp}$ in order to select the AM mode.

Suppressed Carrier Modulation (SCM)

In this mode, the Model 95 functions like the AM mode, except the Model 95 suppresses the output level to 0V with no external signal supplied. Three scale factors (V_{out}/V_{in}) aid in determining the input to output signal level. SCM can only be selected when the Continuous signal level is $<7.5V_{pp}$.

Frequency Modulation (FM and VCG)

In the FM mode, an external signal controls the frequency of the generator. Connecting a dc level to the Trig/Freq In connector shifts the generator to a frequency based on the magnitude of the level. Connecting an ac signal to the Trig/Freq In deviates the frequency of the generator about its programmed frequency. The Model 95 only can be frequency modulated a maximum of three decades on a fixed range. Internal or external phase lock is not selectable in this mode.

Sweep

In this mode, the Model 95's frequency varies between start and stop frequencies. The unit linearly or logarithmically sweeps the frequency up to three decades on a selected range. The Model 95 provides five sweep modes: sweep start, sweep stop, continuous sweep, triggered sweep, or manually sweep. Sweep time is programmed from 100 ms to 100s. Start/Stop frequency accuracies are $<\pm 3\%$. All 50% symmetrical waveforms can be swept.

1.3.3 Frequency

Range

1mHz to 20 MHz,
20 Hz to 20 MHz, synthesized,
1mHz to 1MHz, 600 Ω or balanced output.

Resolution

4 digits

Accuracy

- ± 10 ppm synthesized:
20 Hz to 20 MHz Continuous, AM, or SCM modes.
- $\pm 3\%$ of setting non-synthesized:
1mHz to 20 Hz Continuous, AM, or SCM mode;
1mHz to 20 MHz, top decade of each frequency range in triggered, gated, burst, FM, or sweep mode.
- $\pm 5\%$ of setting non-synthesized:
1mHz to 20 MHz, lower two decades of each frequency range in the FM or sweep mode.

Stability

- VS temperature:
 ± 2 ppm/ $^{\circ}C$ for synthesized ($0^{\circ}C$ to $50^{\circ}C$);
 <100 ppm/ $^{\circ}C$ for non-synthesized.

VS time:

- ±20 ppm/year for synthesized,
- ±0.5% for non-synthesized within 24 hours;
- ±0.1% for non synthesized within 10 minutes.

Internal Phase Lock

The Model 95 can be phase locked at frequencies >20 Hz (Continuous, AM or SCM mode) to an internal crystal referenced frequency synthesizer which improves the generator's frequency accuracy and stability.

External Phase Lock

The Model 95 phase locks (frequencies above 20 Hz: Continuous, AM, or SCM mode) to an external source. Model 95 measures the external signal, sets the generator's frequency, and locks the generator to the source. The external source controls the generator's frequency, stability, and purity.

Also, external phase lock permits programmable phase shift ($\pm 180^\circ$ or $\pm \pi$ radians) with 1° resolution. Phase lock accuracy (50Hz to 10 MHz) is $\pm(4^\circ + 20 \text{ ns})$ accuracy. If the external source has dc offset, the Model 95 ignores the offset.

1.3.4 Amplitude

Range

1mVpp to 15Vpp terminated into selected output impedance;
2mVpp to 30Vpp into an open circuit.

Resolution

4 Digits: 2mVpp to 20Vpp Open Circuit (minimum 1mV),

1mVpp to 10Vpp Terminated ;

4 1/2: 20Vpp to 30Vpp Open Circuit,

10Vpp to 15Vpp Terminated.

Offset waveforms may reduce amplitude resolution.

Accuracy

Percent of settings for all functions at 1kHz:

±(2% + 1mV), to 100 mVpp terminated;

±(2% + 2mV), to 1Vpp terminated;

±(2% + 10mV), to 15Vpp terminated.

Flatness (50Ω or 75Ω)

Relative to 1kHz:

Unbalanced 50Ω

<2MHz

±0.3dB, sine and square;

±0.5dB, triangle.

2MHz to 20MHz

±0.75dB, sine and square;

±1.5dB, triangle.

Balanced 135Ω

<100 kHz

±0.3dB, sine.

100 kHz to 1MHz

±0.75dB, sine.

1.3.5 Offset

Range

±7.5 V terminated;
±15 V open circuit.

Resolution

4 digits; programming both offset and amplitude may reduce resolution.

Accuracy

±(1% of reading + 1mV), 0 to 10 mV terminated;
±(1% + 2mV), 10 mV to 1V terminated;
±(1% + 10 mV), 1V to 7.5V terminated.

1.3.6 Outputs

Sync Output

Sync Out is a female BNC connector which supplies a TTL compatible synchronizing pulse output. The sync signal is at programmed frequency and symmetry and in phase with the square function. Output level is >2Vpp to <0.4Vpp into 50Ω termination. The 10% to 90% transition times are less than 11ns. When using Arb functions, the Sync Address key sets an Arb Address.

Sweep Output

Sweep Out is a female BNC connector, which supplies a 0 to +5V ramp to indicate sweep position. Source impedance is 600Ω. Sweep Output is active only with the sweep modes.

Unbalanced Output

Unbalanced output is a female BNC connector which is the source of programmed waveform at selected frequency, amplitude, symmetry, and offset. Source impedance is 600Ω ± 1% to 1 MHz, 50Ω ± 1%, or 75Ω ± 1% to 20 MHz. The unbalanced output can not be used with the balanced output.

Balanced Output

Balanced outputs are dual "banana jack" connectors which provide differential outputs. A universal binding post provides a signal common "center tap" connection. Source impedance is programmable as 135Ω ± 0.5% or 600Ω ± 1% to 1 MHz. The balanced output can not be used with the unbalanced output.

Z-Axis Output

Z-Axis Out is a rear panel BNC connector for scope Z-Axis (intensity) modulation during Arb editing. Select the Z-Axis characteristics to match the scope's Z-Axis input. The Model 95 produces an output of 150 mVp to 4Vp (50Ω termination) with positive pulse and selectable polarity (logic sense not amplitude).

1.3.7 Inputs

Trigger/Frequency Input

Trig/Freq In is a female BNC connector serves two functions. In trigger, gated, burst, and trigger sweep modes it accepts the signal that will trigger the generator. The input signal must be either TTL or bipolar (600 mVpp to 30Vpp) with a frequency range of dc to 20 MHz. Minimum pulse width is 50ns.

In phase lock, Trig/Freq In accepts the signal that phase locks the Model 95 to the external source. The Model 95 measures the frequency, sets the unit to match the source frequency, and phase locks the generator to the source. Model 95 phase locks range from 20Hz to 20 MHz in the Continuous, AM or SCM modes. The input signal must be a sine wave or bipolar signal (600 mVpp to 30Vpp).

Input impedance is 10 kΩ ± 2%.

Modulation In

Mod In, a female BNC connector, serves as the modulation input for FM (VCG), AM, and SCM. Input impedance is $10\text{ k}\Omega \pm 2\%$. Bandwidth is dc to 100 kHz. Maximum input level is $\pm 20\text{ V}_{pp}$ (into $10\text{ k}\Omega$).

FM Mode: In FM an external signal provides linear control of waveform frequency around the programmed frequency. A $\pm 10\text{V}$ input signal causes a 1000:1 (three decade) frequency change on the selected frequency range. An ac signal varies the frequency around the programmed frequency. A dc level shifts the generator to its new frequency. VCG bandwidth is dc to 100 kHz limited by $0.06\text{ V}/\mu\text{s}$ maximum slew rate. FM bandwidth is dc to 100 kHz deviation rate; with maximum envelope distortion of 1.78% (-35 dB). Envelope distortion is measured using 10 MHz carrier frequency, 1kHz modulation frequency and 1MHz (10%) depth (sine wave modulation).

AM Mode: In the AM mode an external signal provides linear control of waveform amplitude around the programmed amplitude value. Displayed amplitude dependent scale factor specifies approximate V_{pp} (into $10\text{k}\Omega$) required for 100% modulation. AM bandwidth is dc to 1MHz; with a maximum envelope distortion of 2% taken with 1MHz carrier frequency, 1 kHz modulation frequency and 70% AM (sine wave modulation).

SCM (Suppressed Carrier Modulation): In the SCM mode, an external signal linearly controls of the waveform's amplitude about the zero carrier level. The Model 95 displays a scale factor ($2\text{V}/\text{V}$, $0.2\text{V}/\text{V}$, or $0.02\text{V}/\text{V}$) which defines the amount of Mod In signal level to produce a SCM output level. SCM bandwidth is dc to 1MHz. Maximum envelope distortion is 2% (1MHz carrier and 1kHz modulation).

1.3.8 Display

The Model 95 contains a 16 digit, Vacuum Florescent Display (VFD) with 14 segment, alphanumeric characters and 11 mm character height. The display shows all selectable parameters, parameter name, numeric value and the unit of measure. In addition, the display shows GPIB messages, various utilities, maintenance, and diagnostic information.

1.3.9 GPIB Programming

Address

The Model 95 accepts GPIB addresses of 0 to 30 (default is 9). Addresses are front panel selectable and retained in battery backed memory.

Subsets

SH1, AH1, SR1, RL1, PP0, DC1, DT0, C0, T6, L4, TE0, LE0 and E1.

1.3.10 Arbitrary Waveform Generator

The Model 95's Arbitrary Waveform Generator (Arb) allows the user to create and store up to four unique waveforms. The Model 95 transfers the selected Arb waveform from storage RAM to the active RAM. The storage RAM contains four waveform blocks of up to 8K points with start and stop addresses, sync position and a Z-Axis marker. The Model 95 samples the Arb waveform in the active RAM using a clock derived from the function generator's frequency/period. The waveform may be from 2 samples to the full 8K samples in width. The RAM's battery allows the Model 95 to retain waveforms with the power off. The unit accepts Arb waveforms via the GPIB which the unit stores in its active RAM. These waveforms can be edited and stored in memory.

Horizontal Resolution: 2 words to 8K words per waveform for each of four waveforms.

Vertical Resolution: 12 bits (4096 points)

Analog Filter: Two pole active Bessel filter, programmable as no filter, 5MHz corner, and 50 kHz corner.

Digital Filter: A smoothing function that acts like a single pole, low pass filter which alters waveform data. Eight filter weights adjust the smoothing algorithm. The Model 95 displays the equivalent bandwidth.

Flatness: $\pm 0.5\text{dB}$ referenced to 1kHz sample waveform. Waveform: 10 point 2MHz sine wave (20 MHz sample frequency), no filter or the 5 MHz cut-off filter .

Transition Times: $< 20\text{ns}$ for a full amplitude step (no filter programmed).

Editing: The Model 95 offers four methods of editing the Arb waveforms: point, line, three-point, and block.

Point editing allows the user to change a single point without affecting the other points.

Line editing allows the user to "draw a line" between two user-defined points (address/data). The Model 95 erases all previous data between the points.

Three-point allow the user to pick a point between left and right cursors and alter the waveform by "pulling" the point around.

Block edits allow the user to place a "standard" waveform (dc, triangle, square, ramp up, and ramp down, sine, cosine, inverse sine, and inverse cosine) between left and right cursors. Use any of the other edit methods to change the block waveform. In block edit mode, the amplitude and offset keys change the relative amplitude and offset. Also in the block edit mode, the Model 95 allows inversion of the selected part of the waveform.

Arb Sync: Sync Out (TTL) pulse marks a position within the Arb waveform block. The Sync Address key selects the sync address. The Model 95 stores the sync address with the Arb waveform.

Z-Axis Out: Z-Axis Out, a rear panel BNC connector, provides a Z-Axis (intensity) output during Arb editing. The Model 95 allows selection of Z-Axis characteristics to match the scope's Z-Axis input: 100 mVpp to 4Vp (50 Ω termination) positive pulse with selectable polarity (logic sense).

Trigger, Gate, and Burst of the Arb Waveform: Arb waveforms can be triggered, gated, and burst the same as the function generator. A single cycle of the Arb waveform is the time between the start and stop addresses.

1.4 OPTIONS

001: Frequency Reference — This option improves the accuracy and stability of the Model 95's reference oscillator. This option consists of an adjustable crystal (TCXO) with a ± 1 ppm performance over the operating temperature range. The Option 001 also includes an external reference input connector and reference output connector. The reference input accepts a 10 MHz, TTL or Bipolar signal which overrides the internal reference. The reference output supplies a 10 MHz, TTL pulses which can drive a 50 Ω termination.

002: Extended Arb RAM — This option expands the Arb waveform RAM. It increases the active RAM from 8K to 32K. This option also enlarges the storage RAM.

003: Handles and Rack Adapter — This option consists of a pair of handles and rack adapters. Rack adapters allow mounting of the Model 95 in a standard 19 inch rack.

004: Extended Cards – This option supplies a set of extender card which provide access to the daughter boards during maintenance.

1.5 GENERAL

1.5.1 Physical Specifications

Dimensions

35.6 cm (14.in.) wide, 13.3 cm (5.219 in.) high and 43.2 cm (17 in.) deep.

Weight

About 7.7 kg (17 lb.) net; 11.8 kg (26 lb.) shipping.

Power

90 to 108, 108 to 126, 198 to 231, or 216 to 252 Vrms; 48 to 440 Hz; 1 phase; <100 VA.

1.5.2 Environmental Specifications

The Model 95 conforms to MIL-T-28800C, class 5.

Temperature Range

0°C to +50°C for operation;

-40°C to +70°C for storage.

Warm Up Time

Allow 20 minutes for specified operation at temperature of last Auto Cal $\pm 10^\circ\text{C}$. Auto Cal should be performed when the ambient temperature has changed.

Operational Humidity

11°C to 30°C at 95% relative humidity;

31°C to 40°C at 75% relative humidity;

41°C to 50°C at 45% relative humidity.

Altitude

To 10,000 ft. (3050m.) for operation;

To 15,000 ft. (4570m.) for non-operating.

Vibration (Operating)

Vibration level of 0.013 in. from 5 to 55 Hz (2g acceleration at 55 Hz.).

Shock (Non-operating)

40g, 9ms half-sine wave.

Bench Handling (Operating)

4 in. or point of balance drop, any face, solid wooden surface.

Electromagnetic Compatibility

The Model 95 has been tested to MIL-STD-461A Notice 4 (EL) and meets the emission and susceptibility requirements of CE02, CE04, CS02, CS06, RE02, RE02.1, and RS03.

SECTION 2

PREPARATION

This section contains the following elements:

Receiving and Inspecting Shipments	Paragraph 2.1
Returning equipment for repair	Paragraph 2.2
Preparation for storage or shipment	Paragraph 2.3
Preparation for use	Paragraph 2.4
Functional Checkout	Paragraph 2.5
Routine Maintenance	Paragraph 2.6

2.1 RECEIVING AND INSPECTING SHIPMENTS

Use the following steps to inspect a shipment of Wavetek equipment.

1. **Inspect the shipment.** Before unpacking the instrument, the receiving clerk should check the shipment for missing boxes, inspect each box for damage, and if necessary, have the driver describe the box damage and list shortages on the delivery bill. If you find unreported shortages or damage, notify the shipper before further unpacking.
2. **After unpacking the boxes.** Save all of the packing material.
3. **Inspect the equipment for damage.** Inspect it carefully, regardless of the condition of the shipping boxes.
4. **If necessary, file a damage claim.** If any damage is found, call the shipper immediately (within 10 days) and start the claim process.
5. **Call Wavetek.** Call Wavetek's Customer Service department (619-279-2200) and tell them that the equipment arrived damaged.

2.2 RETURNING EQUIPMENT FOR REPAIR

Use the following steps when returning Wavetek equipment to Wavetek for repair.

1. **Save the packing material.** Always return the equipment to Wavetek in its original packing material and boxes. If you use inadequate packing material, you will have to pay to repair any shipping damage as carriers will not pay claims on incorrectly packed equipment.
2. **Call Wavetek for a Return Authorization.** Wavetek's customer service representative will ask for the name of the person returning the equipment, telephone number, company name, equipment type and serial number, and a description of the problem.

2.3 PREPARATION FOR STORAGE OR SHIPMENT

2.3.1 Packaging

If at all possible, always use the original shipping container. However, when using packing materials other than the original, use the following guidelines:

Wrap the Model 95 in plastic packing material.
Use a double-walled cardboard shipping container.
Protect all sides with shock absorbing material (minimum of 2 inch thick material) to prevent movement of the Model 95 within the container.
Seal the shipping container with approved sealing tape.
Mark "FRAGILE" on all sides, top, and bottom of the shipping container.

2.3.2 Storage

The Model 95 should be stored in a clean, dry environment. In high humidity environments, protect the Model 95 from temperature variations that could cause internal condensation. The following environmental conditions apply to both shipping and storage;

Temperature	-40°C to +70°C
Relative Humidity (sea level)	Less than 95% at +25°C.
Altitude	Less 15,000 feet (4570 meters).
Vibration	Less than 2g.
Shock	Less than 40g.

2.4 PREPARATION FOR USE

Paragraph 2.4 covers the following topics

- Power and Fuse Selection
- Installation
- Initial turn
- Power ON,
- Maintenance and Error codes,
- Auto-Cal and Calibrate.

2.4.1 Power and Fuse Selection

NOTE

Unless otherwise specified at the time of purchase, this instrument was shipped from the factory with the power transformer connected for operation on 108 to 126 Vac line with a 1 amp fuse.

Conversion to other input voltage requires a change in rear panel fuse holder voltage card position and fuse (figure 2-1) according to the following procedure.

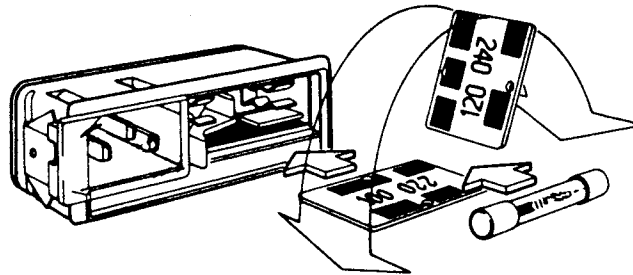

Figure 2-1 . Voltage Selector and Fuse

1. Disconnect the power cord at the instrument, open the fuse holder cover door and rotate the fuse-pull to the left to remove the fuse.
2. Read the voltage on the voltage selection printed circuit card inside the power/fuse case. Leave the card installed if the number matches the voltage needed (see the table below). To change to a different voltage, pull the card and reinsert it as shown in figure 2-1.

Card Position	Input Vac	Fuse
100	90 to 105	1A, 250Vac, Slo Blo
120	108 to 126	1A, 250Vac, Slo Blo
220	198 to 231	1/2A, 250Vac, Slo Blo
240	216 to 252	1/2A, 250Vac, Slo Blo

3. Compare the ampere rating on the fuse to the ampere ratings given in the previous table for the range of input voltages. If the fuse has the right rating, keep it. If the fuse has the wrong rating, replace it.
4. Rotate the fuse pull lever back into the normal position, insert the correct fuse, and close the cover door.
5. Connect the ac line cord to the mating connector at the rear of the unit and power source.

2.4.2 Installation

The Model 95 is primarily for bench use. For operating convenience, the Model 95 has a bail that can be adjusted to elevated the instrument.

Also, the Model 95 can be rack mounted using the two mounting ears which are available as Option 003. To install the mounting ears, remove the two handle screws (each side) install the ears along with the handles using the longer screws supplied with the ears.

2.4.3 Initial Turn On

WARNING

The Model 95 Signal Generator is equipped with a three-wire power cable. When connected to a grounded ac power receptacle, this cable grounds the instrument front panel and cabinet. Do not use extension cords or ac adapters without a ground.

WARNING

This instrument uses internal batteries that contain more than 0.2 grams of Lithium. Do not charge or short this battery. A hazard of explosion and or contamination exists.

1. Verify that only the power cable is connected to the Model 95. All other cables should be disconnected.
2. Set the Power On/Off switch from Off to On.

When power is first applied, the Model 95 performs a Self-test which checks the internal battery, Motherboard memory, Arb Active memory, and storage memory. If there are Self-test errors they will be displayed; see table 2-1. If the unit passes Self-test, it will display "WAVETEK MODEL 95".

Table 2-1. Maintenance Messages and Error Codes.

Display	Probable Cause	Corrective Action
Err xxxxxxxx	Improper self-check/unit	Press POWER key OFF and then ON. If identical failure error is displayed, refer to section 6 (Maintenance). If a different error displayed, press the Calibrate key again. If "WAVETEK 95" is displayed, the unit is operational.
Low batt x.xxx v	Internal battery voltage low.	Unit is available for immediate operation. Refer to section 6 for battery replacement.
Cal Required	Internal battery dead.	Unit has lost its calibration data but can be used after performing and passing AutoCal. Instrument may not meet all specifications.

3. Press the SHIFT key and RESET ALL key (2). The display lists the options installed. Verify the following front panel conditions exist by pressing the key and viewing the display or annunciator:

Key	Default Condition
Frequency/Sample	1kHz (1ms)
Amplitude	5Vpp (2.5Vp, 1.768Vrms, or 18dBm)
Offset	0Vdc
Symmetry	50%
Store	Last stored setting
Recall	Last stored setting
Phase	0° (0 radians)
Trigger/Lock Source	Internal source
Trigger Frequency	100Hz
Burst Count	5
Function	Sine
Mode	Continuous
Sweep Mode	

Start	1kHz
Stop	10 kHz
Time	1s (1Hz) Sweep time
Linear/Logarithmic	Linear
Trigger Frequency	100Hz (10 ms)
On/Off	Output Off (Impedance indicator flashes)
Select (output)	50Ω, Unbalanced
Knob	Disabled

5. If all above conditions are correct, the signal generator is ready for operation. If a condition is incorrect, notify your maintenance department or return the instrument to Wavetek for repair.

2.4.4 Auto Cal and Calibrate

The Model 95 permits two forms of calibration: Auto Cal and Calibrate.

Auto Cal (automatic calibration) provides a quick method of calibrating the Model 95 without using external test equipment. Auto Cal automatically sets up the instrument and takes internal measurements using internal standards. The Model 95 calculates correction values based on the measurements and stores those values in memory. These correction values are recalled from memory when the unit is powered up. Use Auto Cal when accuracy is critical, after long term instrument storage, following drastic changes in the environment, or when the operator believes Auto Cal is necessary.

After the Model 95 has warmed up for at least 20 minutes, perform the following steps:

1. Press the CALIBRATE key (SHIFT and CALIBRATE). The display shows "CALIBRATING". If the CALIBRATE key is pressed before the 20 minute warm up time has elapsed, the display shows the time until the Auto Cal starts.
2. At the end of the Auto Cal cycle the display will show "AUTOCALIBRATED" if the cycle is successful. If there are errors the display will show them. See section 6 for a listing of those errors.

Calibrate provides a more extensive method of calibrating the Model 95 using external test equipment. Calibrate does require opening the instrument and making adjustments. Use Calibrate when the Model 95 displays "CAL REQUIRED" or "ERR XXXXXXXX", when the Model 95 has been repaired, or when routine calibration is scheduled. Section 5 of this manual covers Calibration. Typically, the calibration cycle is 1 year.

2.4.5 Maintenance Messages and Error Codes

Some internal circuit failures cause maintenance messages or error codes to appear in the display. See table 2-1 for a list of possible maintenance messages/error codes and probable cause.

2.5 FUNCTIONAL CHECKOUT

The functional checkout provides a quick method of verifying the operation of the Model 95. The only test equipment required to perform this checkout will be a signal (modulation and trigger) source (Wavetek Model 20 or equivalent), an oscilloscope (Tektronix 2445 - dual channel or equivalent), and the appropriate cables and loads. The bold numbers in the checkout refer to items in figure 3-1 and table 3-1; for more information on the operation of the keys and connectors refer to section 3.

Connect the Model 95 to the oscilloscope and signal source; see figure 2-2.

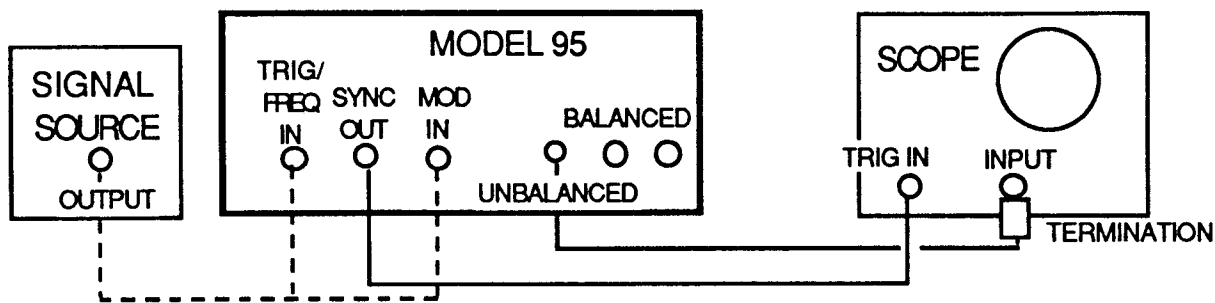

Figure 2-2. Function Checkout Interconnection

FUNCTION CHECK

1. After connecting the power cable, press the POWER switch (1) to turn the Model 95 on. After Self test the display shows "WAVETEK MODEL 95". The output will be off. Terminate the UNBALANCED output (35) with a 50Ω termination.
2. Press SHIFT key (31) and RESET ALL key (2). The Model 95 displays the installed option numbers.

Press the ON/OFF (36) to turn on the output.

Scope displays 1kHz, 5Vpp sine wave.

3. Press the FUNCTION key (15) to step through the triangle, square, and four Arb waveforms, and dc as shown on the scope. The Arb function displayed depend on what was previously stored. Press function and to the sine function.

FREQUENCY CHECK

4. Press the FREQ/SAMP key (4). Press the KNOB key (39) - ENABLE indicator (40) lit.
5. Rotate the knob (41) CW the frequency increases.
Rotate the knob CCW the frequency decreases.
6. Using the keypad (39) press 5 EXP 4 and ENTER to change the frequency to 50 kHz.

AMPLITUDE CHECK

6. Press the AMPLITUDE key (5). Press the KNOB key (39) - ENABLE indicator (40) lights.
7. Rotate the knob (41) CW; the amplitude increases.
Rotate the knob CCW; the amplitude decreases.
8. Using the keypad (39) press 5 and ENTER to change the amplitude back to 5Vpp.

MODE CHECK

9. Trigger Press the MODE key (22) until the TRIG indicator (23) lights.
The internal trigger source is the default - trigger frequency is 100 Hz.
Scope displays a 50 kHz sine wave triggered at a 100Hz rate
10. Connect the signal source to the TRIG/FREQ IN (12) connector.
Set the signal source to 100Hz, 1Vpp square wave.

11. **Gate** Press TRIG/LOCK SOURCE key (11) and use the knob or TRIG/LOCK SOURCE key to select External Source.
Press the MODE key (22) and select the GATE mode - GATE indicator (23) lights.
Scope displays a gated output as long as the triggering signal is true.
12. **Burst** Press the MODE key (22) and select the BURST mode - BURST indicator (23) lights.
Press BURST CNT key (24), press the KNOB key (39) - ENABLE indicator (40) lit, and use the knob to change the count from 5 to 2.
Scope displays a burst of 2 sine waves.
13. **Amplitude Modulation** Press the MODE key (22) and select the AM mode - AM indicator (23) lights.
Connect the signal source to the MOD IN connector (30). Set the signal source to 100Hz, 1Vpp sine wave; trigger the scope from the signal source.
Scope displays an AM signal.
14. **Suppressed Carrier Modulation** Press the MODE key (22) and select the SCM mode - SCM indicator (23) lights.
Scope displays a SCM (double side-band) signal.
15. **Frequency Modulation** Press the MODE key (22) and select the FM mode - FM indicator (23) lights.
Scope displays a FM signal.
16. **Sweep Mode** Disconnect the signal source.

Press the MODE key (22) and select the Sweep mode - Sweep indicator (23) lights.

Press the SWEEP MODE key (26) and display the sweep start frequency.

Rotate the knob until 200Hz is displayed.

Press the SWEEP MODE key (26) and display the sweep stop frequency.

Press the SWEEP MODE key (26) and CONTINUOUS SWEEP is displayed.

Connect the Model 95's SWEEP OUT (29) to the scope's trigger input. Select external trigger on the scope.

Scope displays 200 Hz to 10 kHz sweep at a 1 second rate.

PHASE SHIFT

17. Press the MODE key (22) and select the continuous mode - CONT indicator (23) lights.

Press the TRIG/LOCK SOURCE key (11) and select the external source.- EXT indicator (10) lights and UNLOCK indicator (9) flashes.

Set the signal source 2kHz, 2Vpp sine wave.

Connect the signal source output to the TRIG/FREQ IN connector (12) - UNLOCK indicator (9) goes out. The Model 95 displays EXTLOC 2.000 KHZ. Trigger the scope from the signal source.

Press the PHASE key (8). Rotate the knob CW, the phase of the waveform on the scope increases. Rotate the knob CCW, the phase of the waveform on the scope decreases.

BALANCED OUTPUT

18. Press the key combination of SHIFT (31) key and SELECT key (36) until the both the 600Ω and BAL indicators (37) light.
19. Press the AMPLITUDE key (5) and use the knob to set the output level to 10 Vpp.
20. Connect the balanced output to the scope inputs as shown in the following figure.

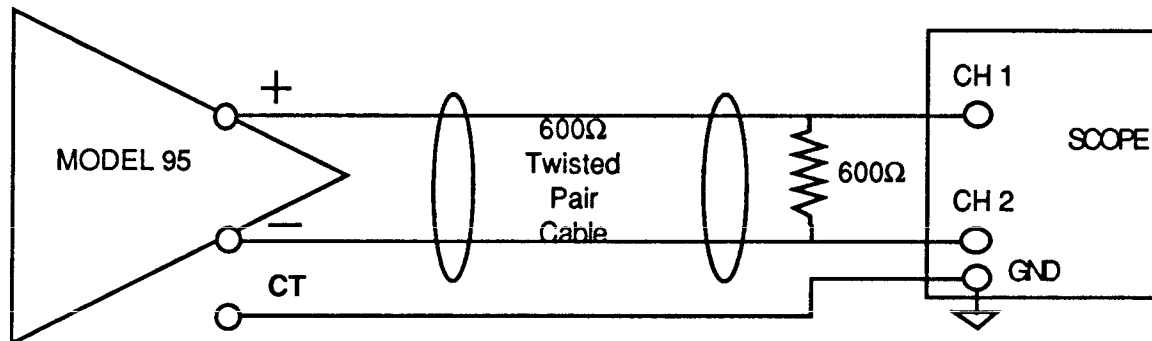

BALANCED OUTPUT

Scope Setup:

CH 1 and CH 2 - dc coupled, adjust so both waveforms have same amplitude about the horizontal center line.

Change VERT MODE to ADD and invert CH 2.

- 21 View balanced output on scope.

2.6 ROUTINE MAINTENANCE

No tools or equipment are required for routine routine maintenance. The cleaning materials are listed below:

Description	National Stock Number
Isopropyl Alcohol MIL-A-10428, Grade A (81349)	6810-00-753-4993
Lintless Cotton Cheesecloth CCC-C-440, Type II, Class 2 (81349)	8305-00-267-3015
Mild Liquid Detergent	

Routine maintenance for the Model 95 is limited to routine checks such as listed below;

- Cleaning,
- Dusting,
- Wiping,
- Checking for frayed cables,
- Storing items not in use,
- Covering unused receptacle,
- Checking for loose nuts, bolts, and screws.

Perform these routine check anytime they need to be done.

FAN MAINTENANCE

The Model 95 contains a fan which is located on its right side. Located on the outside of the unit is the filter for the fan. This filter should be cleaned about every month; more often if the unit is used in a dusty environment.

To clean the Filter,

1. Disconnect the Model 95 from the primary power source.
2. Using a screwdriver, gently pry off the Filter's grill.
3. Remove the foam filter.
4. Clean the foam filter using a mild soapy solution. Thoroughly rinse the filter, and allow it to dry.
5. Place the filter back in the unit, and snap in the Filter's grill.
6. Connect the Model 95 to the primary power source.

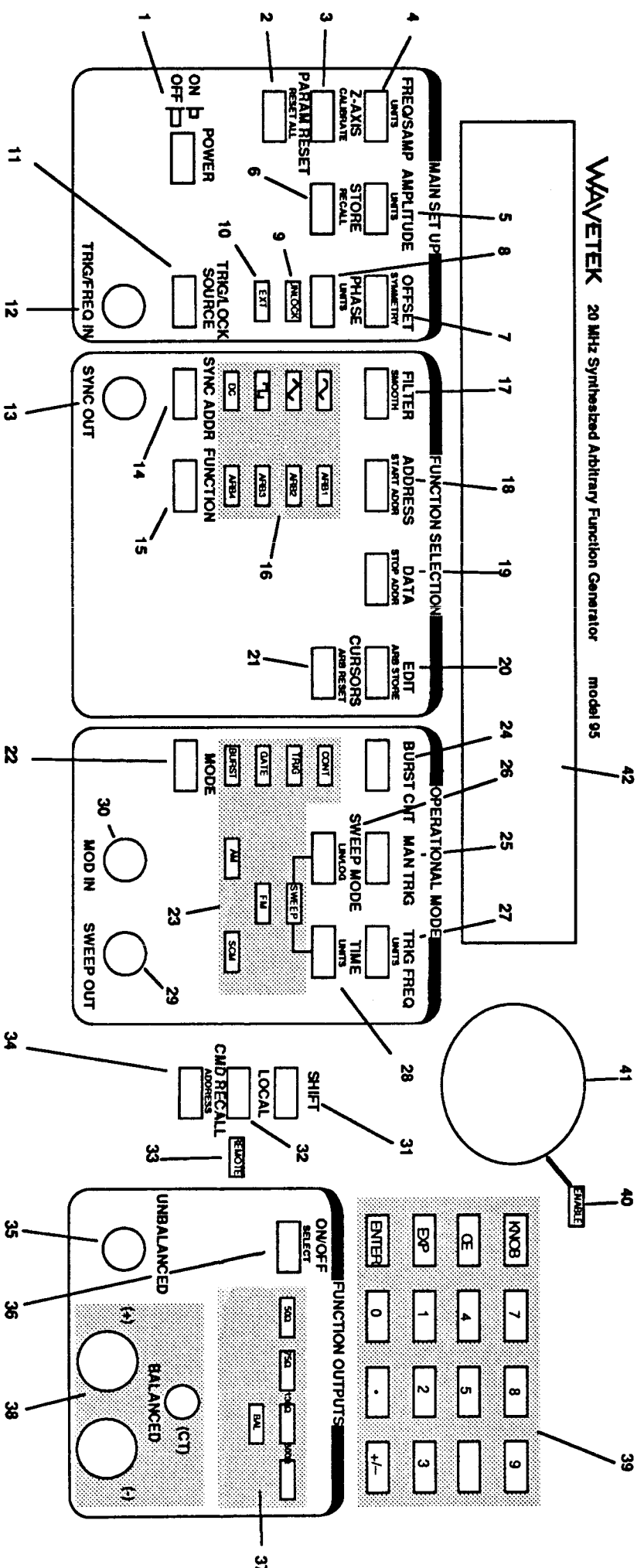

Figure 3-1. Model 95 Front Panel Controls and Connectors

SECTION 3

OPERATION

3.1 INTRODUCTION

This section provides operator information for the Model 95 Arbitrary/Function Generator and is organized as follows:

- Paragraph 3.2 describes the unit's controls (keys and menus) and connectors.
- Paragraphs 3.3 and 4.3 describe the Model 95's GPIB commands.
- Paragraph 3.5 provides detailed instructions on how to set up the Model 95 for various tasks.

3.2 CONTROLS CONNECTOR AND INDICATORS

Paragraph 3.2.1 describes of the Model 95's front panel "Controls, Indicators, and Connectors". Paragraph 3.2.2 explains the Model 95's rear panel.

3.2.1 Front Panel Controls, Indicators, and Connectors

Figure 3-1 identifies the Model 95's front panel controls and connectors. The numbers in figure 3-1 are used throughout this section as well as throughout the manual to identify the keys and connectors. Table 3-1 describes the function of each control and connector of the Model 95.

Table 3-1. Front Panel Controls, Indicators, and Connectors

Key	Control, Indicator or Connector	Function
MAIN SET UP Group		
1	POWER switch	This switch turns the Model 95's power on or off. Pressing the button in turns the power on. Extending the button turns the power off. At power on, the Model 95 first performs a Self-Test which tests the motherboard memory, Arb active memory, and storage memory, and checks the internal battery, and then returns the unit to its last setup (the output will be off).
2	PARAM RESET key	Press this key to reset the currently displayed parameter to its default value; see Model 95 Default Conditions. This does not change non-displayed parameters.
	RESET ALL key	Press the SHIFT key and then the RESET ALL key to reset all Model 95 parameters to their default conditions.

Table 3-1. Front Panel Controls, Indicators, and Connectors (continued)

Key	Control, Indicator or Connector	Function																																														
		Model 95 Default Conditions																																														
		<table border="0"> <thead> <tr> <th style="text-align: left;">Key</th> <th style="text-align: left;">Condition</th> </tr> </thead> <tbody> <tr> <td>Frequency/Sample</td> <td>1kHz (1ms)</td> </tr> <tr> <td>Amplitude</td> <td>5Vpp (2.5Vp, 1.77Vrms, 18dBm)</td> </tr> <tr> <td>Mode</td> <td>Continuous</td> </tr> <tr> <td>Offset</td> <td>0V</td> </tr> <tr> <td>Symmetry</td> <td>50%</td> </tr> <tr> <td>Store</td> <td>Last location stored</td> </tr> <tr> <td>Recall</td> <td>Last location stored</td> </tr> <tr> <td>Phase</td> <td>0° (0 radians)</td> </tr> <tr> <td>Trigger/Lock Source</td> <td>Internal</td> </tr> <tr> <td>Burst Counter</td> <td>5</td> </tr> <tr> <td>Filter</td> <td>None</td> </tr> <tr> <td>Function</td> <td>Sine</td> </tr> <tr> <td>Sweep Mode</td> <td>Continuous Sweep</td> </tr> <tr> <td>Sweep Start</td> <td>1kHz</td> </tr> <tr> <td>Sweep Stop</td> <td>10 kHz</td> </tr> <tr> <td>Time</td> <td>1s Sweep</td> </tr> <tr> <td>Linear/Logarithmic</td> <td>Linear Sweep</td> </tr> <tr> <td>Trigger Frequency</td> <td>100Hz</td> </tr> <tr> <td>On/Off</td> <td>Output Off (50Ω indicator flashes)</td> </tr> <tr> <td>Select output</td> <td>50Ω, Unbalanced</td> </tr> <tr> <td>Knob</td> <td>Disabled</td> </tr> <tr> <td>Edit</td> <td>Edit Off</td> </tr> </tbody> </table> <p>The following keys are not affected by the RESET ALL key:</p> <ul style="list-style-type: none"> Arb Store Calibrate Address Start Address Data Stop Address Smooth Z-Axis Man trigger Local Sync Address GPIB Address Arb Reset Cursors 	Key	Condition	Frequency/Sample	1kHz (1ms)	Amplitude	5Vpp (2.5Vp, 1.77Vrms, 18dBm)	Mode	Continuous	Offset	0V	Symmetry	50%	Store	Last location stored	Recall	Last location stored	Phase	0° (0 radians)	Trigger/Lock Source	Internal	Burst Counter	5	Filter	None	Function	Sine	Sweep Mode	Continuous Sweep	Sweep Start	1kHz	Sweep Stop	10 kHz	Time	1s Sweep	Linear/Logarithmic	Linear Sweep	Trigger Frequency	100Hz	On/Off	Output Off (50Ω indicator flashes)	Select output	50Ω, Unbalanced	Knob	Disabled	Edit	Edit Off
Key	Condition																																															
Frequency/Sample	1kHz (1ms)																																															
Amplitude	5Vpp (2.5Vp, 1.77Vrms, 18dBm)																																															
Mode	Continuous																																															
Offset	0V																																															
Symmetry	50%																																															
Store	Last location stored																																															
Recall	Last location stored																																															
Phase	0° (0 radians)																																															
Trigger/Lock Source	Internal																																															
Burst Counter	5																																															
Filter	None																																															
Function	Sine																																															
Sweep Mode	Continuous Sweep																																															
Sweep Start	1kHz																																															
Sweep Stop	10 kHz																																															
Time	1s Sweep																																															
Linear/Logarithmic	Linear Sweep																																															
Trigger Frequency	100Hz																																															
On/Off	Output Off (50Ω indicator flashes)																																															
Select output	50Ω, Unbalanced																																															
Knob	Disabled																																															
Edit	Edit Off																																															

Table 3-1. Front Panel Controls, Indicators, and Connectors (continued)

Key	Control, Indicator or Connector	Function
3	Z-AXIS key	Press the Z-AXIS key to select intensity modulation signal supplied by the Model 95 that will match the scope used. Press the Z-AXIS key or use the knob to select the value.
4	CALIBRATE key	Press the SHIFT key and then the CALIBRATE key to perform the Model 95's Auto Cal. Autocal performs a functional check and fine tuning of certain internal circuits. During Auto Cal the display shows "CALIBRATING", and "AUTOCALIBRATED" when finished with Auto Cal. The Model 95 must be allowed to warm up 20 minutes after power is applied before Auto Cal can be performed.
	FREQ/SAMP key	<p>Press the FREQ/SAMP key to display the current generator frequency or Arb sample rate. Use the control knob or numeric keypad to change the frequency or sample rate. The control knob, if enabled, automatically enters the new value. When using the keypad to enter values, press the ENTER key.</p> <p>Function Generator - When the sine, triangle, and square functions are selected, the Model 95 operates as a function generator. Pressing the FREQ/SAMP key displays the output frequency or period (selected by the frequency's UNITS key). Displayed frequency units are MHz, kHz, Hz, and mHz, and displayed period units are SEC and ms. Range is from 1mHz to 20.00 MHz or 1000.0s to 50ns with four digits of resolution. Default is 1.000 kHz.</p> <p>Specified Frequency Limits: 2MHz when symmetry is not 50%, 1MHz when 600Ω Unbalanced is selected, 1MHz when 135Ω Balanced is selected, 1MHz when 600Ω Balanced is selected.</p> <p>Arb Generator - When user-defined functions (ARB1, ARB2, ARB3, and ARB4) are selected, the Model 95 operates as an Arb generator. Pressing the FREQ/SAMP key displays the Arb sample rate or waveform rate (selected by the frequency's UNITS key).</p>
	UNITS key	<p>Press the SHIFT key and then the (FREQ/SAMP) UNITS key to change the units of measure for the FREQ/SAMP key.</p> <p>Function Generator - When this key sequence is performed, the current selection is displayed. Use the knob to scroll through the list (Frequency or Period); press the ENTER key to accept the desired item.</p>

Table 3-1. Front Panel Controls, Indicators, and Connectors (continued)

Key	Control, Indicator or Connector	Function
5	AMPLITUDE key	<p>Arb Generator - When this key sequence is performed, the current selection is displayed. Use the knob to scroll through the list (Sample Frequency, Sample Period, Block Frequency, and Block Period), press the ENTER key to accept the desired item.</p> <p>Press the AMPLITUDE key to display the current output level. Use the control knob or keypad to change the output level. The control knob automatically enters the new value. When using the keypad, press the ENTER key to accept the new value. Amplitude units (see below) can be Vpp, Vp, Vrms, or dBm with up to four digits of resolution. Output level (based on the Unit selected) can be</p> <ul style="list-style-type: none"> 1mVpp to 15.0 Vpp, 0.5mVp to 7.5 Vp, 0.4mVrms to 5.3 Vrms, -56.0 dBm to +27.5 dBm. <p>Default value is 5 Vpp.</p> <p>Amplitude Limits</p> <ul style="list-style-type: none"> Offset values limit the amplitude. AM limits the maximum AM amplitude to one half the Continuous amplitude. SCM sets the programmed level to 0V; output level depends on magnitude of the modulating signal. Vpp and Vp are the only units of measure when dc offset is not 0Vdc and symmetry is not 50%. <p>Pressing the Amplitude key in Arb edit allows adjustment only the amplitude (Digital Amplitude) a portion, set by the left and right cursors, of the Arb waveform. Digital amplitude is expressed in percent (1% to 100%) instead of volts.</p>
	UNITS key	<p>Press the SHIFT key and then the (AMPLITUDE) UNITS key to step between Vpp, Vp, Vrms, and dBm. Performing this key combination displays the current selection. Use the knob or SHIFT/UNITS to step through the list (Vpp, Vp, Vrms, and dBm), and press the ENTER key to accept the displayed item.</p>
6	STORE key	<p>Press the STORE key to store a complete front panel instrument setup. Pressing the key displays the last storage location. Use the numeric keypad or knob to select a storage location (1 to 10). Press ENTER to transfer the setup to the storage location. To retrieve stored settings, use RECALL key .</p>

Table 3-1. Front Panel Controls, Indicators, and Connectors (continued)

Key	Control, Indicator or Connector	Function
7	RECALL key	Press the SHIFT key and then the RECALL key to select a stored instrument setup. Use the knob or numeric keypad to select a storage location, then use the ENTER key to initiate that instrument setup
	OFFSET key	<p>Press the OFFSET key to display the current dc offset level. Use the control knob and numeric keypad to change the dc offset value. The knob automatically enters the new value. When using the keypad, press the ENTER key to accept the new value. DC offset levels can be programmed between +7.500V to -7.500V. The default value is 0Vdc. Offset values are limited to $\text{Offset} + V_p \leq 7.5V$.</p> <p>In dc function, OFFSET controls the output polarity and level. In other functions Offset varies the reference level of the selected function.</p> <p>Offset Limits Selecting the Balanced output fixes the offset at 0Vdc. Selecting AM or SCM limits the offset range to 1/2 of the maximum programmed offset. The amplitude value limits the offset value.</p> <p>Pressing the Offset key in Arb edit allows adjustment only the offset (Digital offset) a portion, set by the left and right cursors, of the Arb waveform. Digital offset is expressed in a value relative (± 2047) to the position of the left cursor instead of volts.</p>
	SYMMETRY key	<p>Press the SHIFT and then the SYMMETRY key to display the current waveform symmetry value. Symmetry values are expressed in percent (%) and can be varied between 5% and 95% in 1% increments. Use the knob and keypad to change the waveform symmetry value. The control knob automatically enters the new value. When using the keypad, press the ENTER key to accept the new value. The default is 50%.</p> <p>Selecting BAL, FM (VCG), or Sweep fixes the symmetry at 50%. The symmetry range decreases linearly between 2MHz and 20 MHz at 20 MHz the symmetry is fixed at 50%.</p>

Table 3-1. Front Panel Controls, Indicators, and Connectors (continued)

Key	Control, Indicator or Connector	Function
8	PHASE key	Press PHASE key to display the current selected phase shift. Use the control knob and keypad to change the phase relative to the TRIG/FREQ IN signal. The control knob automatically enters the new value. When using the keypad, press the ENTER key to accept the new value. The phase can be varied from +180° to -180° (+3.14 to -3.14 radians) with 3 digits of resolution. Default is 0°. Use the UNITS key to shift between degrees and radians.
	UNITS key	Press the SHIFT key and the (PHASE) UNITS key to display the current unit of measure for phase. Use the knob or SHIFT/UNITS combination to step from Degrees to Radians; press the ENTER key to accept the selection.
	UNLOCK indicator	When this indicator is off, the unit is locked to either the internal or external frequency reference. A flashing indicator signifies an external reference is not connected, or the internal reference has a problem. A continuously lit indicator means the current instrument setup does not allow locking to a frequency reference.
10	EXT indicator	When on, it indicates external reference or trigger source must be connected to the TRG/LOCK IN connector. It does not indicate signal is present at the connector.
11	TRG/LOCK SOURCE key	<p>This key serves two functions based on the unit's operating mode.</p> <p>Continuous , AM , and SCM modes - Press the TRG/LOCK SOURCE key to select either the Model 95's internal (synthesizer) phase lock source or an external phase lock source.</p> <p>Selecting the internal phase lock source displays the Model 95's synthesizer frequency.</p> <p>Selecting the external phase lock source displays the frequency of the signal at the TRIG/FREQ IN connector. At frequencies above 20 Hz the Model 95 measures the input frequency, sets its frequency to match, and locks itself to the external source.</p>

Table 3-1. Front Panel Controls, Indicators, and Connectors (continued)

Key	Control, Indicator or Connector	Function
12	TRIG/FREQ IN connector	<p>TRIG, GATE, or BURST mode - Use this key to select either the internal (synthesizer) trigger source or an external trigger source. Press this key to toggle between Internal and External sources.</p> <p>Selecting the internal trigger source displays the trigger frequency (TRIG FREQ key). The internal trigger source's frequency range is 1mHz to 20 MHz.</p> <p>Selecting the external trigger source displays the frequency of the signal at the TRIG/FREQ IN connector. Frequency range for external trigger source is dc to 20 MHz.</p> <p>This is the input connector for the trigger or phase lock source. Input impedance is 10kΩ. Input signal can be either a logic level or bipolar sine wave.</p> <p>Phase Lock - To phase lock, the external source must be between 20Hz and 20 MHz, and the level must be 600 mVpp to 30Vpp or TTL level. The Model 95 automatically sets its frequency to match the external source. In addition, the Model 95 displays the frequency of the external source.</p> <p>External Trigger - The signal must be between dc and 20 MHz, and the level must be 600 mVpp to 30Vpp or TTL level. .</p>
FUNCTION SELECT Group		
13	SYNC OUT connector	<p>The signal from this output connector may be used to synchronize external equipment to the Model 95. Output impedance is 50Ω. The output signal is a TTL pulse.</p> <p>Function Generator - The Sync signal will be the same frequency as the output waveform frequency. The symmetry is same as square wave and "in phase" with square wave but leads sine and triangle waveforms by 90°. There will not be a Sync Out signal for the dc function.</p> <p>ARB Generator - The Sync signal occurs once per Arb waveform at an address selected using the SYNC ADDR key. The waveform or sample rate determines the sync frequency.</p>

Table 3-1. Front Panel Controls, Indicators, and Connectors (continued)



Key	Control, Indicator or Connector	Function
14	SYNC ADDR Key	Press this key to select the sync address for the Arb waveform. An Arb function must be selected. Use the knob or keypad to change the address (0 to 8191). However, the selectable address range actually depends upon the Start and Stop Addresses of the selected Arb waveform. The control knob automatically enters the new address. When using the keypad, press ENTER to accept the new address.
15	FUNCTION key	<p>Press the FUNCTION key to select the output waveform. Press and hold this key to cycle the unit through its functions (sine, triangle, square, dc, ARB 1, ARB 2, ARB 3, and ARB 4). A lit indicator identifies the selected function. Release the function key to select a function.</p> <p>To step backwards through the functions, press the SHIFT key and then hold down the FUNCTION key. Release the FUNCTION key when the indicator lights to select the function.</p> <p style="text-align: center;">CAUTION</p> <p>Pressing the FUNCTION key while editing an Arb waveform will automatically store the waveform back into the Arb Memory. To avoid this use Undo Edit: see the EDIT key.</p>
16	<p>DC indicator</p> <p> (square) indicator</p> <p> (triangle) indicator</p> <p> (sine) indicator</p> <p>ARB 4 indicator</p> <p>ARB 3 indicator</p>	<p>When on, indicates that dc function is selected. To activate, press the FUNCTION key (15) until indicator lights. The dc function cannot be selected when Balanced output, AM mode, or phase lock on is selected.</p> <p>When on, indicates the square function is selected. To activate, press the FUNCTION key (15) until indicator lights.</p> <p>When on, indicates the triangle function is selected. To activate, press the FUNCTION key (15) until indicator lights.</p> <p>When on, indicates the sine function is selected at the Unbalanced or Balanced output connector. To activate, press the FUNCTION key (15) until the indicator lights.</p> <p>When on, indicates the arbitrary waveform number 4 is selected. Use the FUNCTION key (15) to step to this function.</p> <p>When on, indicates arbitrary waveform number 3 is selected. Use the FUNCTION key (15) to step to this function.</p>

Table 3-1. Front Panel Controls, Indicators, and Connectors (continued)

Key	Control, Indicator or Connector	Function
17	ARB 2 indicator	When on, indicates arbitrary waveform number 2 is selected. Use the FUNCTION key (15) to step to this function.
	ARB 1 indicator	When on, indicates arbitrary waveform number 1 is selected. Use the FUNCTION key (15) to step to this function.
	FILTER key	Press the FILTER key to display the current analog, low-pass filter used with the selected Arb waveform. Use the control knob or FILTER key to step through the filter selections: "Filter None", "Filter 5MHz", "Filter 50 kHz". Filter selection affects the Arb bandwidth.
18	SMOOTH key	Press the SHIFT key and the SMOOTH key to select software smoothing or averaging of the selected arbitrary waveform.
	ADDRESS key	Press this key to display the last programmed Arb waveform address and the data for that address. Addresses range from 0 to 8191. If Option 002 is installed the addresses range from 0 to 32,767. This key is only active when an arbitrary waveform is selected.
19	START ADDR key	Changing Addresses - Use the knob or keypad to locate a desired address. The knob automatically enters the new address. When using the keypad, press the ENTER key to accept the new address. Press the SHIFT key and then the START ADDR key to display the current Arb waveform start address. Use the knob and keypad to enter a new start address which must be less than the stop address. The knob automatically enters the new start address. When using the keypad, press the ENTER key to accept the new value. Start addresses range from 0 to 8190. If Option 002 is installed the start addresses range from 0 to 32766.
	DATA key	Press this key to display the last programmed Arb waveform data value and the address for that data. Data values can be from -2047 to +2047. This key is only active when an arbitrary waveform is selected. Changing Data - After an Arb waveform address has been selected using the ADDRESS key (18), use the knob or keypad to enter the new data. The knob automatically enters the new data. When using the keypad, press the ENTER key to accept the new data.

Table 3-1. Front Panel Controls, Indicators, and Connectors (continued)

Key	Control, Indicator or Connector	Function
21	<p>ARB STORE</p> <p>CURSOR key</p> <p>ARB RESET key</p>	<p>Block allows a "block" waveform to be inserted between the left and right cursors of an Arb waveform. "Block" waveforms are dc, triangle, square, + ramp, - ramp, + sine, - sine, + cosine, - cosine, and inverted. Once the standard waveform is inserted in the Arb waveform, the waveform can be edited using any of the other three techniques. Use the Amplitude key to set the digital amplitude, and use the Offset key to set the digital offset.</p> <p>Undo Edit permits the user to return to the original unedited waveform, providing the edited waveform has not been stored. The edited waveform will be lost.</p> <p>Press the SHIFT key and the ARB STORE key to store the currently edited waveform in one of the four nonvolatile Arb waveform storage locations. Use the knob to scroll through the list: ARB 1, ARB 2, ARB 3, and ARB 4. Press the ENTER key to accept the location.</p> <p>In Arb edit modes, this key allows selection of the left and right cursors. After selecting a cursor, enter a cursor address using the knob or keypad. Valid cursor addresses are 0 to 8190. If Option 002 is installed the addresses range from 0 to 32,766.</p> <p>Press the SHIFT key and then the ARB RESET key to initialize the active RAM. The active RAM resets immediately to all zeros at all addresses. In addition, the cursors reset to the last selected start and stop addresses. In three point edit, the Model 95 places a cursor in the middle of the line.</p>
OPERATIONAL MODE Group		
22	MODE key	<p>Press the MODE key to step through the Model 95's operating modes:</p> <ul style="list-style-type: none"> Cont (continuous) Trig (triggered) Gate (gated) Burst AM (amplitude modulation) SCM (Suppressed Carrier Modulation) FM (frequency modulation) SWEEP <p>To step backwards through the modes, press the SHIFT key and then hold down the MODE key. Release the MODE key when the indicator lights to select the mode.</p>
23	CONT indicator	<p>When on it indicates the continuous mode is active. Use the MODE key (22) to select this mode.</p>

Table 3-1. Front Panel Controls, Indicators, and Connectors (continued)

Key	Control, Indicator or Connector	Function
	TRIG indicator	When on it indicates the triggered mode is active. The Model 95 must be triggered to initiate a trigger cycle. Use the MODE key (22) to select this mode.
	GATE indicator	When on it indicates the gated mode is active. The Model 95 must be triggered to initiate a gate cycle. Use the MODE key (22) to select this mode.
	BURST indicator	When on it indicates the burst mode is active. Use the BURST CNT key (24) to enter the number of bursts. The Model 95 must be triggered to initiate a burst cycle. Use the MODE key (22) to select this mode.
	AM indicator	When on, it indicates that AM modulation mode is active. An external signal source connected to MOD IN connector (30) is required for AM operation. Use the MODE key (22) to select this mode. AM can not be selected when the sum of amplitude (Vpp) and Offset (Vdc) exceeds 7.5V.
	SCM indicator	When on, it indicates the Suppressed Carrier Modulation mode is active. An external signal source connected to MOD IN connector (30) is required for SCM operation. Use the MODE key (22) to select this mode.
	FM Indicator	When on, it indicates that FM/VCG modulation mode is active. An external signal source connected to MOD IN connector (30) is required for FM/VCG operation. Use the MODE key (22) to select this mode. FM can not be selected when symmetry is not 50% or the generator is in external phase lock.
	SWEEP indicator	When on, it indicates that sweep mode is active. Use the MODE key (22) to select this mode. Use the SWEEP MODE key (26) to set the start frequency, stop frequency, sweep conditions. Sweep can not be selected when the symmetry is not 50% or the generator is in external phase lock.
24	BURST CNT Key	Press the BURST CNT key to display the currently selected burst count. Use the knob or keypad to change the burst count. The knob automatically enters the new value. When using the keypad, press the ENTER key to accept the new value. Burst count values range from 1 to 1,000,000 cycles.
25	MAN TRIG key	Press this key to manually trigger the generator. In the triggered mode, the generator produces one complete cycle of the waveform each time the key is pressed.

Table 3-1. Front Panel Controls, Indicators, and Connectors (continued)

Key	Control, Indicator or Connector	Function
26	SWEEP MODE key	<p>In the gated mode, the generator produces continuous waveforms as long as the key is held in. When the key is released, the waveforms stop.</p> <p>In the burst mode, the generator produces the preset number (Burst Count) of cycles each time the Man Trig key is pressed.</p> <p>In the triggered sweep mode, the generator sweeps from the start frequency to the stop frequency each time the Man Trig key is pressed.</p> <p>Press the SWEEP MODE key to step through a list of sweep related items: sweep start, sweep stop, sweep run, triggered sweep, and manual sweep.</p> <p>The Model 95 limits the sweep range to three decades. If the sweep start frequency is set and the sweep stop frequency exceeds the three decade limit, the start frequency will be pulled up. If the sweep stop frequency is set and the sweep start frequency exceeds the three decade limit, the stop frequency will be pulled down.</p> <p>Sweep Start displays and sets the generator to the currently selected sweep start frequency. The unit displays sweep start frequency in mHz, Hz, kHz, and MHz. The sweep start frequency range is from 1mHz to 20 MHz. Default is 1kHz. Use the knob and keypad to change the sweep start frequency. The knob automatically enters the new sweep start frequency. When using the keypad, press the ENTER key to accept the new sweep start frequency.</p> <p>Sweep Stop displays and sets the generator to the currently selected sweep stop frequency. The unit displays the sweep stop frequency in mHz, Hz, kHz, and MHz. The sweep stop frequency range is from 1mHz to 20 MHz. Default sweep start frequency is 10 kHz. Use the knob and keypad to change the sweep stop frequency. The knob automatically enters the new sweep stop frequency. When using the keypad, press the ENTER key to accept the new sweep stop frequency.</p> <p>Continuous Sweep allows the Model 95 to continuously sweep between the sweep start frequency and the sweep stop frequency. The TIME key (28) sets the repetition rate of the sweep. The sweep mode must be selected.</p>

Table 3-1. Front Panel Controls, Indicators, and Connectors (continued)

Key	Control, Indicator or Connector	Function
27		<p>Triggered Sweep allows the Model 95 upon receipt of a trigger to sweep between the sweep start frequency and the sweep stop frequency. The TIME key (28) sets the rate of the sweep. Sweep mode must be selected.</p>
		<p>Manual Sweep allows operator to manually sweep the Model 95 between the sweep start frequency and the sweep stop frequency using the knob or the keypad. The sweep mode must be selected.</p>
	LIN/LOG key	<p>Press the SHIFT and the LIN/LOG key to display the current sweep type. LIN allows the unit to linearly sweep from the start to the stop frequency. LOG allows the unit to exponentially sweep between the start to the stop frequency. Use the knob or SHIFT and LIN/LOG key to change the sweep type.</p>
	TRIG FREQ key	<p>Press the TRIG FREQ key to display the current internal trigger frequency. Use the knob or the keypad to change the trigger frequency. The knob automatically enters the new trigger frequency. When using the keypad, press the ENTER key to accept the new trigger frequency. Internal trigger frequency range is 1mHz to 20 MHz. Use the TRG/LOCK SOURCE key (11) to select the internal trigger source.</p>
	UNITS key	<p>When using the Triggered Sweep Mode, the internal trigger frequency ranges is 0.01 to 10 Hz.</p> <p>Press the SHIFT and then the (TRIG FREQ) UNITS key to display the units of measure for the trigger frequency. Use the knob or SHIFT and UNITS key to toggle between Frequency and Period.</p>
28	TIME key	<p>Press this key to display the currently selected sweep time. The sweep time range is 0.1 to 100 seconds. Default is 1 second. Use the knob or the keypad to change the sweep time. The knob automatically enter the new sweep time. When using the keypad, press the ENTER key to accept the new sweep time.</p>
	UNITS key	<p>Press the SHIFT key and then the (TIME) UNITS key to display the time units of measure. Use the knob or SHIFT and UNITS key to toggle between Frequency or Period.</p>

Table 3-1. Front Panel Controls, Indicators, and Connectors (continued)

Key	Control, Indicator or Connector	Function
29	SWEEP OUT connector	This BNC connector supplies a 5Vp linear ramp proportional to the sweep output. The beginning of the ramp represents the start frequency and the end of the ramp represents the stop frequency. Output level is 0 to +5V for sweep up or +5V to 0V for sweep down. The sweep rate depends on the selected sweep time. Output impedance is 600Ω. Use this output as an external sweep or horizontal signal source. The sweep out signal is only present during sweep modes.
30	MOD IN/OUT connector	<p>This connector receives modulation input for the AM, SCM, and FM modes. Input impedance is 10kΩ.</p> <p>FM - The signal modulates the frequency of the generator. A ±10V signal varies the frequency a maximum of 1000:1 frequency change on the same range. When FM is selected the Model 95 locks on to the same range. The frequency (dc to 100 kHz) of the external signal controls the modulation rate. When MODE: FM is selected, the Model 95 displays the scale factor: XXXX Hz/Volt (input).</p> <p>AM - The signal modulates the output level of the generator; the generator provides the carrier. The unmodulated output level will be one-half the programmed level. The frequency range of the source is dc to 1MHz. When MODE: AM is selected, the Model 95 displays the scale factor: XXXX V(input) = F.S. (100% modulation).</p> <p>SCM - The signal modulates the output level of the generator; the generator provides the carrier. The unmodulated output level will be 0V regardless of the output level. When MODE: SCM is selected, the Model 95 displays a scale factor: X V/V (Vin/Vout). Where X represents 2V/V, 0.2V/V, or 0.02V/V which are selected using the knob. SCM output level depends on the magnitude of the modulating signal. The frequency range of the source is dc to 1MHz.</p>
SHIFT/LOCAL/REMOTE		
31	SHIFT key	Press the SHIFT key to select alternate key items, which are shown in blue on the front panel just under the major item.
32	LOCAL key	Pressing this key returns the Model 95 to front panel control from the remote (GPIB) mode. Front panel displays "GOTO LOCAL". Press to activate. This key is inactive if the external controller enables "Local Lockout".
33	REMOTE indicator	When on, indicates that an external GPIB controller controls the Model 95. In this mode, the Model 95 can be queried but settings cannot be changed.

Table 3-1. Front Panel Controls, Indicators, and Connectors (continued)

Key	Control, Indicator or Connector	Function
38	135Ω indicator	When on, it indicates 135Ω balanced output impedance. Use the SELECT key (36) to select 135Ω.
	600Ω indicator	When on, it indicates 600Ω balanced or unbalanced output impedance. Use the SELECT key (36) to select 600Ω.
	BAL indicator	When on, it indicates the Balanced output connectors are the selected generator outputs. When off, it indicates the Unbalanced output connector is the selected generator output. Use the SELECT key (36) to select the output.
	BALANCED output	The balanced (differential) output consists of two jacks BALANCED (+) and (-) and one center tap (CT) terminal. The BALANCED (+) jack provides the positive (in phase) balanced output. The BALANCED (-) provides the negative (180° phase) balanced output. Output impedance between the (+) and (-) terminals can be 135Ω or 600Ω. Use the SELECT key (36) to select the BALANCED output; BAL indicator is lit.
KEYPAD		
39	Keypad	Press these keys to enter a 0, 1, 2, 3, 4, 5, 6, 7, 8, or 9 for numeric data entry. Use them with +/-, Decimal, Enter, EXP (exponent), and CE (clear entry) keys to enter data. Press desired digit. Parameters that have not be entered using the ENTER key are preceded with *
	+/- key	Press this key to enter a positive or negative sign for numeric data entry. Used for standard and exponent entry. Blank indicates positive, - indicates negative. Press to change sign.
	. (Decimal) key	Press this key to enter a decimal point for numeric data entry.
	ENTER key	Press this key to accept entries from the keypad. Also, use the ENTER key to accept items from a knob controlled scroll list. The Model 95 disregards all values outside its specifications. Values exceeding resolution are rounded or entered to nearest allowable value. Parameters that have not be entered using the ENTER key are preceded with *
	EXP key	Press this key along with the keypad to enter an exponent. Enter the prefix, press EXP key, then exponent value using Numeric key 0 to 9. Exponent can be entered as a negative by pressing +/- key.
CE key	Press this key to clear a numeric entry error when using the Numeric keys. Unwanted data must be cleared before pressing ENTER key. Press once to clear display of numeric entry.	

Table 3-1. Front Panel Controls, Indicators, and Connectors (continued)

Key	Control, Indicator or Connector	Function
KNOB/DISPLAY		
	Knob key	Press this key to enable or disable the Knob. Also pressing this key moves the flashing digit from least significant digit to most significant digit. After the final digit the flashing digit disappears and the Knob ENABLED indicator (40) goes out; now the Knob is disabled. Default is Knob and flashing digit off.
40	ENABLE indicator	When on, it indicates that Knob will change value in the display. Press the Knob key (39) to activate. ENABLE indicator lights only when the parameter can be changed using the Knob (41).
41	Knob	Rotate the knob to change numeric value of flashing digit as selected by knob key (39). CW rotation increases value, CCW rotation decreases value. Active when ENABLE indicator is on.
42	Display	The display (a 16-digit alphanumeric display with decimal point and minus sign) shows output signal information, entry information, operator messages, and error codes.

3.2.2 Rear Panel Connectors

This paragraph provides information on the location, description, and use of the rear panel connectors. Refer to figure 3-2 for the location of the rear panel controls, indicators, and connectors. Table 3-2 provides the description and use of the rear panel controls, indicators, and connectors.

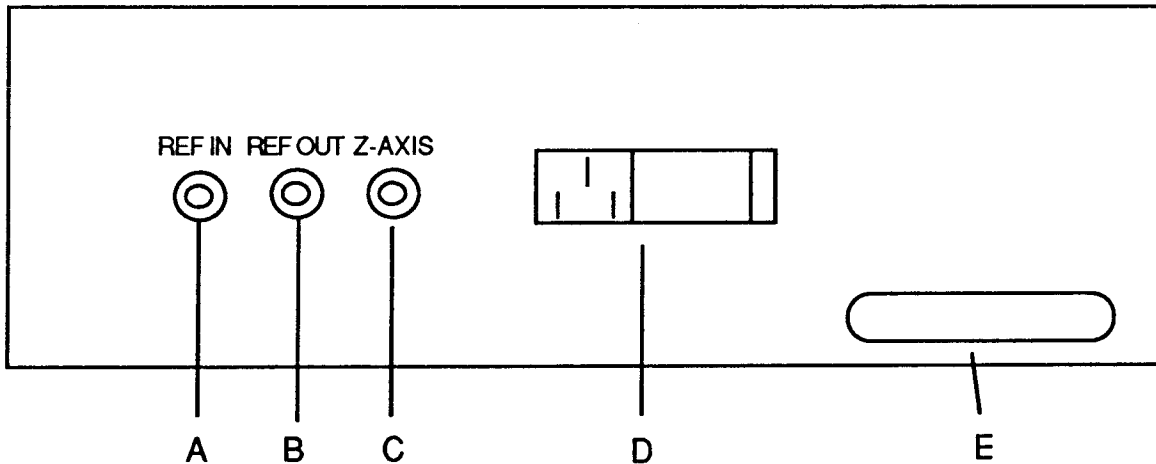

Figure 3-2. Operator's Connectors (rear view)

Table 3-2. Rear Panel Controls and Connectors

Key	Control or Connector	Function
A	REF IN connector	External Reference Input connector - When Option 001 is installed, use this connector to supply an external reference input for the Model 95's internal synthesizer. The external source must be 10 MHz \pm 500 kHz, >500 mVpp.
B	REF OUT connector	Reference Output connector - When Option 001 is installed, use this connector as a 10 MHz, TTL reference source.
C	Z-Axis Out connector	While Arb waveform editing, use the signal from this connector to intensity modulate the Z-axis input of an oscilloscope. Select the output level using the Z-AXIS key (3).
D	Input Power connector	This is the primary ac power input connector for the Model 95. Included within the connector is the line fuse and voltage selector. The input power connector accepts female end of power cable (supplied). A protective grounding conductor connects the Model 95 through this connector. Voltage selection is from 100/120/220/240 Vac. Number visible in window indicates nominal line voltage for which the Model 95 is set to operate. Line power fuse is 1 amp, 250V for 100/120 Vac and 0.5 amp, 250V for 220/240 Vac operation.
E	GPIB connector	Use this connector to mate the Model 95 an external GPIB controller for remote operation. The connector has 24 pins and threaded posts conforming to IEEE-488-1978. Figure 3-3 illustrates the GPIB connector pinouts; see figure 3-3.

3.3 INITIAL GPIB (REMOTE) SETUP

This paragraph describes the initial Model 95 to controller setup for remote (GPIB) operation. The Model 95 digital interface conforms to IEEE 488.1 subsets SH1, AH1, T6, TE0, L4, LE0, SR1, RL1, PP0, DC1, DT0, C0, and E1.

In remote, an external controller transmits commands to the Model 95 and receives commands from the Model 95. Remote operation is similar to local operation (paragraph 3.2) except commands set up the Model 95. GPIB permits remote control of all functions except POWER switch, LOCAL key, and ADDRESS key. Refer to paragraph 3.2 for descriptions of controls, indicators, and connectors. GPIB connector wiring data is shown in figure 3-3.

Model 95 to Controller Setup

Perform the following steps to setup the Model 95 for remote operation.

1. Connect a GPIB interconnect cable between the Model 95 and the controller as shown in figure 3-4. The Model 95's GPIB connector (E) is located on the rear panel of the instrument.

NOTE

Keep GPIB interconnect cable length below 2 meters (6.6 feet)

2. Set the Model 95's GPIB address to match the address used by the controller. To set the GPIB address, press the SHIFT key (31) and then the ADDRESS key (34) to display (42) the current GPIB address. The address is displayed as a decimal value. Use the knob (41) or keypad (39) to change the address. The knob automatically enters the new GPIB address. When using the keypad press the ENTER key (39) to accept the new GPIB address. Addresses range from 00 to 30. Default address is 09. When the controller sets local lockout, the Address key is inactive.
4. Use the controller and GPIB commands (table 3-4) to send a command string to the Model 95.

LOCAL Key

The LOCAL key (32) switches control of the Model 95 from the GPIB bus to the front panel. Receipt of any GPIB command (if the controller simultaneously asserts the REN line of the GPIB) by the Model 95 disables the front panel to the extent that parameter settings can be read but modes or numbers cannot be changed. Pressing the LOCAL key returns full control to the front panel except when the universal command LLO has been issued by the controller. LLO disables the LOCAL key so full control cannot be obtained at the front panel.

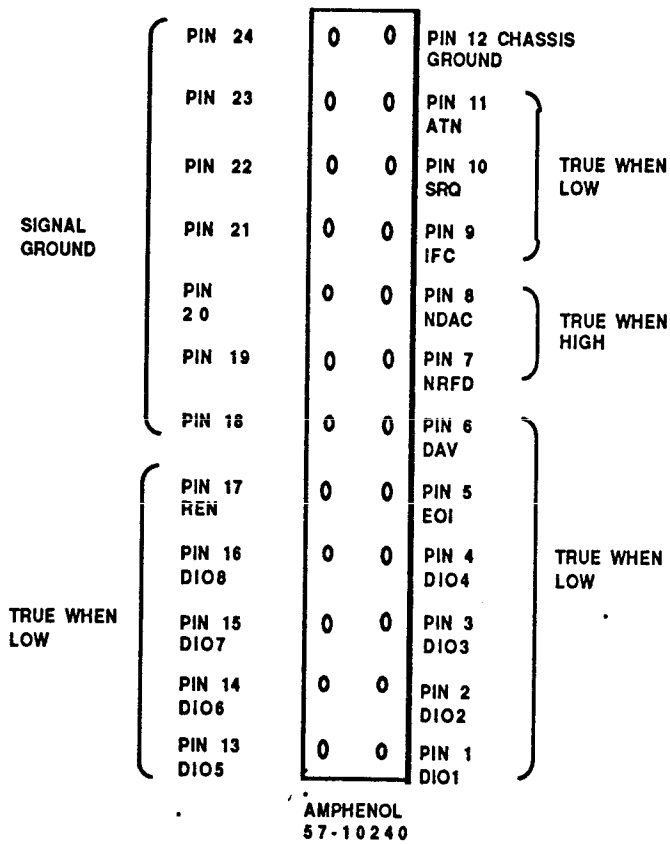

Figure 3-3. GPIB Wiring Connector Pinout

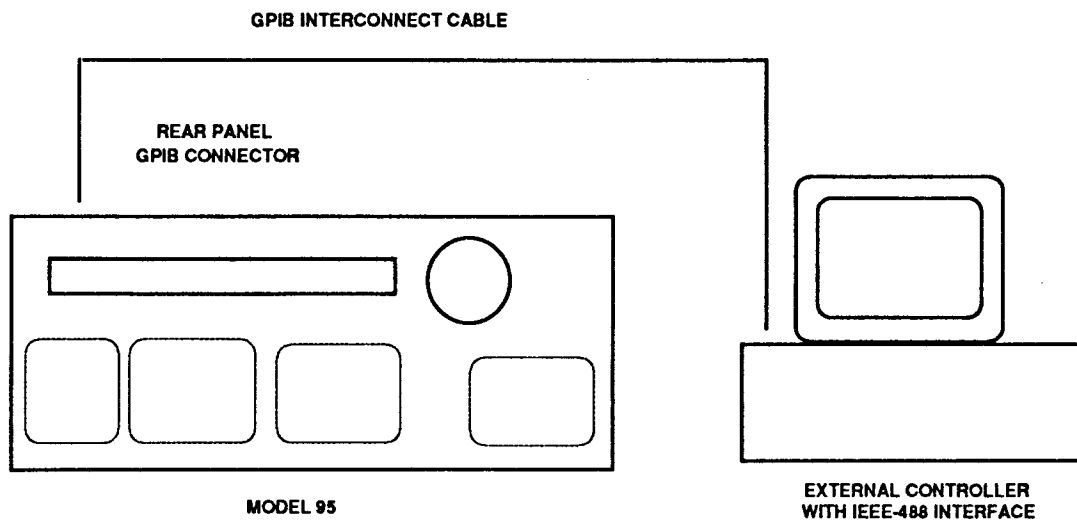

Figure 3-4. GPIB Interconnect Wiring

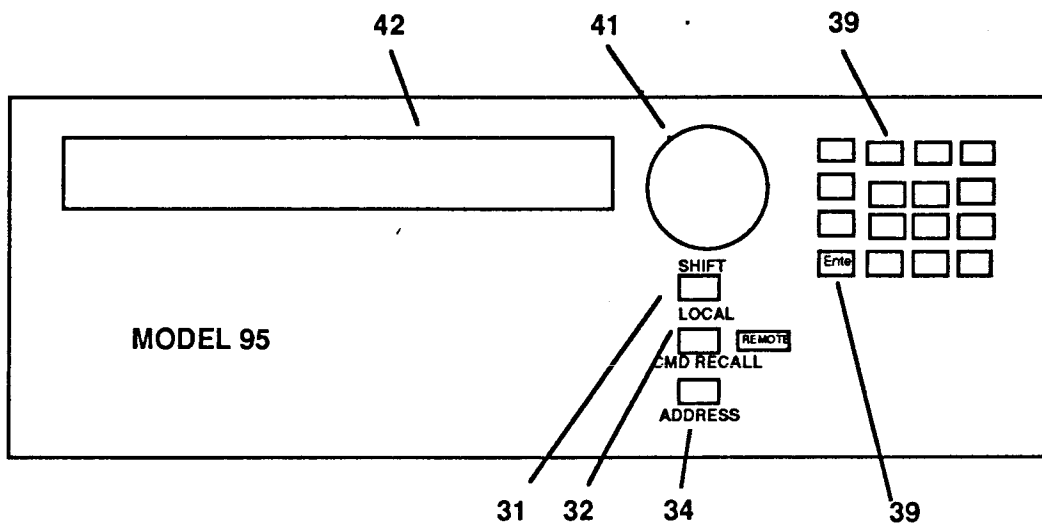

Figure 3-5. GPIB Operation Control Setup

3.4 GPIB COMMAND STRUCTURE

3.4.1 Introduction

Paragraph 3.4 covers the following topics:

- | | |
|----------------------------------|-----------------|
| Model 95 Commands | Paragraph 3.4.2 |
| Universal and Addressed Commands | Paragraph 3.4.3 |
| Detailed Command Descriptions | Paragraph 3.4.4 |
| Service Requests | Paragraph 3.4.5 |
| Displaying Messages | Paragraph 3.4.6 |
| Selftest Query Responses | Paragraph 3.4.7 |

3.4.2 Model 95 Commands

Paragraph 3.4.2 discusses the Model 95 commands and the rules that must be followed to apply them.

Commands Types	Paragraph 3.4.2.1
Command Syntax	Paragraph 3.4.2.2
Command List	Paragraph 3.4.2.3

3.4.2.1 Command Types

The Model 95 has four types of commands: parameter, enumerated, direct, and query. The following text discusses each type. A column in table 3-4 provides a link between the Model 95's GPIB commands and this paragraph. The examples terminate the commands with semicolons (;) or closing quotes ("). The controller may send just the command name without a value and the Model 95 will display that parameter's current value. Replacing the numerical value with a "?" (query) will make the Model 95 display and send the current value to the controller as a string of characters. Do not send an EXECUTE command after a query command, the string will not be sent because the EXECUTE command has put the Model 95 in a "listen for more commands" mode. See "terminators" for more information.

Parameter Commands

Parameter commands specify a particular numerical value within a continuous range of values. The values should use exponential (E) notation.

Format: <header>SPACE<value>TERMINATION

The header specifies the parameter and the value specifies the numerical value. Table 3-4 lists the parameter commands and their allowable value ranges.

Examples

FREQUENCY 2E3;	Sets the frequency at 2kHz.
PHASE 87;	Sets the phase at 87°.
SWEEPTIME 2.3;	Sets the sweep time at 2.3 seconds.

Enumerated Commands

Enumerated commands provide a list of distinct choices. Either the name or numerical value can be used.

Format: <header>SPACE<argument>TERMINATION

The header specifies the parameter and the argument specifies the choice. A number or a descriptive character string can be used for the argument. Table 3-4 lists the enumerated commands and their arguments.

Example

FU 2 or FU SQ Selects square wave.

Direct Commands

Direct commands make the Model 95 perform an immediate action.

Format: <header>TERMINATION

The header specifies the action. Direct commands have no value or argument. Table 3-4 lists all the direct commands.

Examples

RESET;	Resets 95 parameters
TRIGGER;	Triggers waveform or sweep
EXECUTE;	Executes preceding commands in string.
FASTEXECUTE;	Executes the command string without error checking.

Query Commands

Query commands tell the Model 95 to send information to the controller. However, the Model 95 will not send the information when it receives the command, but waits until the controller addresses it as a talker. Only one query command can be sent at a time. If two or more are sent in a query string, the Model 95 responds to the last query.

Format: <header> <?>TERMINATION

The header specifies the type of information. Because all parameter command headers (and most enumerated command headers) can also serve as query headers, the question mark tells the Model 95 to send (rather than receive) the information. Certain other headers appear only in query commands. See Query Commands in paragraph 3.3.2.2, Model 95 Command Syntax for a sample query program.

Parameter Header Examples:

FREQUENCY?;	Returns current frequency.
PHASE?;	Returns current phase.

Enumerated Header Examples:

FUNCTION?;	Returns current output waveform.
OUTPUT?;	Returns current output setting.

Query Header Examples:

MAINPARAMETERS?;	Returns current output waveform.
SRQ?;	Returns current output setting.
STATUSBYTE?;	Returns status byte.

3.4.2.2 Model 95 Command Syntax

Commands sent by an instrument controller to the Model 95 must follow the syntax given in table 3-3. The following text discusses command string operation, command processing, terminators, minimum uniqueness, and query commands.

Command String Operation

The command string works as follows:

```
WRITE @ 709."FR 2E4;OS 1;FU SQ;FR;EX"
```

WRITE @ 709."	This command depends on the controller used.
FR 2E4	Sets the frequency to 20 kHz.
OS 1	Selects unbal 75Ω output .
FU SQ	Selects a square waveform.
FR	Tells the Model 95 to display the frequency value.
EX	Makes the Model 95 convert all these commands to a signal output.

How Does the Model 95 Process Commands?

The Model 95's 256-character listen buffer receives the commands from the instrument controller. If the listen buffer fills up before receiving an EXECUTE command, it will stop accepting commands, distribute its contents to the next-setup registers, then again accept commands. The commands in the next-setup registers will not take effect until the Model 95 receives an Execute.

The listen buffer accepts all commands regardless of syntax errors. When the Model 95 processes the commands in the listen buffer, it copies the defective commands over into the SRQ buffer and labels them with PE:0 to indicate defective syntax. The parameters and functions that the defective commands would have changed remain unchanged. If a command appears in the SRQ buffer, the Model 95 ignores it.

Terminators

A terminator tells the Model 95 that it has reached the end of the current command. The Model 95 recognizes spaces, semicolons (;), and the Execute command as terminators.

When the Space is used, the Model 95 accepts only those good commands up to the defective commands and places all commands (good and bad) after the first defective command in the SRQ buffer.

When Semicolons are used, the Model 95 accepts all commands all good commands and places only the defective commands in the SRQ buffer.

Consider these two examples with and without semicolons (the defective command FR2E4 should read FR 2E4):

With Semicolons

Write @ 709:"FR2E4;OP 1;FU SQ;FR;EX"

Message: SRQ = /PE:0 FR2E4*/

Without Semicolons

Write @ 709:"FR2E4 OP 1 FU SQ FR;EX"

Message: SRQ = /PE:0 FR2E4* OP 1 FU SQ FR EX/

Minimum Uniqueness

The Model 95 will interpret the following three command lines exactly the same. String 1 uses the minimum character set each command requires, string 2 uses longer abbreviations that contain each command's minimum character set, while string 3 completely spells out each command. The expansion of the function command (FU DC, FUNC DC, and FUNCTION DC) demonstrates the use of numbers and descriptive character strings in the argument of enumerated commands. Table 3-4 lists all minimum unique characters for all commands.

String 1:

Write @ 709:"FR 2E4;OP 1;FU 3;FR;EX"

String 2:

Write @ 709:"FREQ 2E4;OUTP 1;FUNC SQR;FREQ ;EXEC"

String 3:

Write @ 709:"FREQUENCY 2E4;OUTPUT 1;FUNCTION SQUARE ;FREQUENCY;EXECUTE"

Query Commands

Query commands (such as FR?) make the Model 95 return the current setting of the parameter as a string of characters and require a program to make the controller use the returned data. The following controller program example requests the data, accepts it, and writes the data to its screen.

Program Statements	Explanation
10 CLEAR	Clear screen
20 WRITE @ 709:"FR?"	Write command to Model 95 (port 7, address 09)
30 DIM STRING\$*25	Dimension string to 25 characters
40 READ @709:STRING\$	Read returning string
50 PRINT STRING\$	Print string to screen
60 END	End program

3.4.2.3 Model 95 Command List

Table 3-4 contains a listing of all Model 95 GPIB commands. Table 3-4 uses the following format to list and briefly describe the complete Model 95 GPIB command set. For information on how the commands work together to perform a task, refer to paragraph 3.5. The following sample from table 3-4 is used to illustrate the columns in the command set.

COMMAND	MIN UNIN.	COMMAND TYPE (¶ 3.4.2.1)	RANGE		DESCRIPTION	ASSOCIATED KEY
			MIN	MAX Value		
FREQUENCY	FR	Parameter	1E-3	20E6	Selects Frequency Hz.	FREQ/SAMP (4)
FREQUENCY?	FR?	Query			Requests current frequency.	FREQ/SAMP (4)
FUNCTION	FU	Parameter	0	7	Selects Function.	FUNCTION (15)

Command Column

This column lists all the commands alphabetically by their full names. Arguments for the commands are indented. In the sample from table 3-4, the Model 95 recognize the full command FREQUENCY.

Minimum Uniqueness (Min. Unin.) Column

Capital letters in this column indicate the minimum letter combination required by the Model 95. In the sample, the minimum command the Model 95 recognize for Frequency is FR. The unit also accepts a longer abbreviation that contains all capital letters FREQ.

Command Type Column

This column list the command types described in paragraph 3.4.2.1. Refer to paragraph 3.4.2.1 to better understand the command syntax.

Range Column

This column contains three parts: minimum value, maximum value, and enumerated value. These are the numeric arguments for the command. The enumerated value represents a numeric value that can be used in place of a minimum unique argument.

Description Column

This column describes the function of the command or argument.

Associated Key Column

This column identifies front panel key which are related to the GPIB command. Not all commands will have an equivalent key.

Other Sources of this Data

The HELP? command provides less complete forms of the data given in table 3-4. HELP? sends a list of all the commands, arguments, and ranges to the GPIB controller.

Table 3-3. Model 95 Command Syntax

Typical Command Line: WRITE @709:"FR 2E4;OP 1;FU SQ;FR;EX"	
Syntax	Explanation
WRITE @709	WRITE @709 is only an example, this command depends on the controller. This format tells the controller to send the command string out port 7 (the GPIB port) to the Model 95 (at address 09 on the GPIB bus).
"__"or '___'	Enclose the command string in quotes. Either single or double quotes can serve as string delimiters.

Table 3-3. Model 95 Command Syntax (Continued)

Typical Command Line: WRITE @709:"FR 2E4;OP 1;FU SQ;FR;EX"

Syntax	Explanation
;	Separate commands with semicolons. See "terminators" in the text for the reasons for this requirement.
E	Use exponent notation to avoid entering long strings of zeros. For example, enter 20000 as 2E4 and 0.0005 as 5E-4.
FR	Use the minimum uniqueness version (FR), a longer version that contains the FREQ minimum uniqueness letters (FREQ), or the full version (FREQUENCY) of each FREQUENCY command in programming. Table 3-4 spells out the commands and indicates the minimum uniqueness with capital letter (FR). The text gives examples of full, partial, and minimum uniqueness command strings.
FU 2	Enumerated commands that select a function (such as FU, select channel output FU SQ waveform) allow the function to be selected by either number (3) or by name (SQ), (square waveform). Table 3-4 lists the enumerated commands and their arguments.
;FR;	Drop the numerical value of a parameter command to make the Model 95 display that parameter. For example, ;A; will display the amplitude. Use this feature in step-by-step operation to follow and verify program operation.
"EX"	Place an Execute command at the end of a command string to make the Model 95 put the commands into effect. The Model 95 will accept commands and put them in the pending setup registers, but it will not generate their output until an EX command is sent. EX also puts the Model 95 in the "listen for more commands" mode; therefore, do not put EX after a query (?) command as it will prevent the Model 95 from returning the answer.
?	Replace the numerical value of a parameter command with a ? to make the Model 95 return the current setting of that parameter as a string of characters. Table 3-4 lists the query commands and shows the format of the returning strings. Query commands also make the Model Model 95 display the menu of the requested parameter. The text gives a short program that makes the controller accept and display the returning information. Do not use EXECUTE after a ? command.

Table 3-4. Model 95 GPIB Command Set

COMMAND	MIN UNIN.	COMMAND TYPE (§ 3.4.2.1)	MIN	RANGE MAX	Value	DESCRIPTION	ASSOCIATED KEY
ADDRESS	AD	Parameter	0	8191		Select Arb address	ADDRESS (18)
ADDRESS?	AD?	Query				Request current Arb address	ADDRESS (18)
AMPLITUDE	AM	Parameter	1E-3	15		Set Amplitude Vpp	AMPLITUDE (5)
AMPLITUDE?	AM?	Query				Request current amplitude	AMPLITUDE (5)
ARBEDIT	ABE	Parameter	0	14		Selects Arb edit mode	EDIT (20)
LINE	L	Enumerated			2	Selects Line edit	
OFF	O	Enumerated			0	Turns off Edit mode.	
POINT	P	Enumerated			1	Selects Point edit	
RESTORE	R	Enumerated			14	Undo Edit	
ARBEDIT?	ABE?	Query				Request current Arb edit model.	EDIT (20)
ARBSTORE	ABS	Parameter	1	4		Store Arb waveform	ARB STORE (20)
ARBPARAMETERS?	ABP?	Query				Requests current Arb Parameters.	
ARBRESET	ABR	Direct				Reset active RAM	ARB RESET (21)
AUTOCALIBRATE	AC	Direct				Start Auto-Calibrate	CALIBRATE (3)
BURSTCOUNT	B	Parameter	1	1E6		Sets number of bursts	BURST CNT (24)
BURSTCOUNT?	B?	Query				Requests current burst count number	BURST CNT (24)
CALIBRATIONDUMP?		Query					
DATA	DA	Parameter	-2047	+2047		Sets Arb data point	DATA (19)
DATA?	DA?	Query				Request last data value.	
DACTEST		Parameter	0	65535			
DCOUT	DC	Parameter	-20	20		In dc function, controls the dc voltage.	OFFSET (7)
DCOUT?	DC?	Query				Request current dc offset value.	OFFSET?
DVMINPUT		Parameter	0	21			
DVM?		Query					

Table 3-4. Model 95 GPIB Command Set

COMMAND	MIN UNIN.	COMMAND TYPE (§ 3.4.2.1)	RANGE			DESCRIPTION	ASSOCIATED KEY		
			MIN	MAX	Value				
EXECUTE	EX	Direct				Executes previous commands	ENTER (39)		
FASTEXECUTE	FE	Direct				Same as Execute, except faster and no error checking			
FILTER	FI	Parameter	0	2		Selects filter.	FILTER (17)		
	L50K	Enumerated			0	Selects 50 kHz filter			
	L5M	Enumerated			1	Selects 5MHz filter.			
	N	Enumerated			2	Selects no filter.			
FILTER?	FI?	Query				Requests current filter.	FILTER (17)		
FREQUENCY	FR	Parameter	1E-3	20E6		Selects Frequency Hz.	FREQ/SAMP (4)		
FREQUENCY?	FR?	Query				Requests current frequency.	FREQ/SAMP (4)		
FUNCTION	FU	Parameter	0	7		Selects Function.	FUNCTION (15)		
	SINE	SI	Enumerated			0		Selects sine function.	
	TRIANGLE	T	Enumerated			1		Selects triangle function.	
	SQUARE	SQ	Enumerated			2		Selects square function.	
	DC	D	Enumerated			3		Selects dc function.	
	ARBWAVEFORM1	AW1	Enumerated			4		Selects Arb waveform 1.	
	ARBWAVEFORM2	AW2	Enumerated			5		Selects Arb waveform 2.	
	ARBWAVEFORM3	AW3	Enumerated			6		Selects Arb waveform 3.	
	ARBWAVEFORM4	AW4	Enumerated			7		Selects Arb waveform 4.	
	FUNCTION?	FU?	Query					Request current function.	
	GATEON	GN	Direct					Gate generator on.	MAN TRIG (25)
	GATEOFF	GF	Direct					Gate generator off.	MAN TRIG (25)
	HELP?		Query					Request a list of GPIB commands.	

Table 3-4. Model 95 GPIB Command Set

COMMAND	MIN UNIN.	COMMAND TYPE (§ 3.4.2.1)	RANGE			DESCRIPTION	ASSOCIATED KEY
			MIN	MAX	Value		
MODE	MO	Parameter	0	7		Selects operating mode.	MODE (22)
CONTINUOUS	C	Enumerated			0	Selects continuous mode.	
TRIGGER	T	Enumerated			1	Selects triggered mode.	
GATE	G	Enumerated			2	Selects gated mode.	
BURST	B	Enumerated			3	Selects burst mode.	
AM	A	Enumerated			4	Selects AM mode.	
SCM	SC	Enumerated			5	Selects SCM mode.	
FM	F	Enumerated			6	Selects FM mode.	
SWEEP	SW	Enumerated			7	Selects Sweep model	
MODE?	MO	Query				Request current mode.	MODE (22)
MAINPARAMETERS?	MP?	Query				Request current main parameters.	
OFFSET	CF	Parameter	-7.5	+7.5		Selects waveform offset voltage (Vdc)	OFFSET (7)
OFFSET?	OF?	Query				Request current offset value	OFFSET (7)
OUTPUT	OP	Parameter	0	1		Turns output on or off.	ON/OFF (36)
OFF	CF	Enumerated			0	Turns output off.	
ON	ON	Enumerated			1	Turns output on.	
OUTPUT?	OP?	Query				Request output condition.	
OUTPUTSELECT	OS	Parameter	0	4		Selects output and impedance	SELECT (36)
UNBALANCED50	U50	Enumerated			0	Selects 50Ω Unbalanced output.	
UNBALANCED75	U75	Enumerated			1	Selects 75Ω Unbalanced output.	

Table 3-4. Model 95 GPIB Command Set

COMMAND	MIN UNIN.	COMMAND TYPE (¶ 3.4.2.1)	RANGE			DESCRIPTION	ASSOCIATED KEY
			MIN	MAX	Value		
UNBALANCED600	U600	Enumerated			2	Select 600Ω Unbalanced output.	
BALANCED600	B600	Enumerated			3	Selects 600Ω Balanced output.	
BALANCED135	B135	Enumerated			4	Selects 135Ω Balanced output	
OUTPUTSELECT?	OS?	Query				Request current output and impedance.	
PHASE	P	Enumerated	-180	+180		Selects phase shift (degrees).	PHASE (8)
PHASE?	P?	Query				Request current phase shift.	PHASE (8)
PARAMETERRESET	PR	Direct				Resets last transmitted parameter	PARAM RESET (2)
RESET	R	Direct				Reset all parameters except Arb and GPIB address.	RESET ALL (2)
RANGELOCK	RA	Parameter	0	1		Locks generator to current freq. range.	
OFF	OF	Enumerated			0	Normal range.	
ON	ON	Enumerated			1	Locks range.	
RANGELOCK?	RA?	Query				Request current range lock condition.	
RECALLSETTING	RCL	Parameter	1	10		Recalls stored settings in selected location.	RECALL (6)
RECALLSETTING?	RCL?	Query				Request last stored setting selected.	RECALL (6)
SELFTEST?	SLFT?	Query				Requests Self Test results.	
SOURCE	SRC	Parameter	0	1		Selects Trigger or Phase Lock source.	TRG/LOCK key (11)
INTERNAL	I	Enumerated			0	Selects internal source	

Table 3-4. Model 95 GPIB Command Set

COMMAND	MIN UNIN.	COMMAND TYPE (¶ 3.4.2.1)	MIN	RANGE MAX	Value	DESCRIPTION	ASSOCIATED KEY
EXTERNAL	E	Enumerated			1	Selects external source	
SOURCE?	SCR?	Query				Requests current source.	
STORESETTING	STS	Parameter	1	10		Stores setup in location selected.	STORE (6)
STORESETTING?	STS?	Query				Request last stored setting.	STORE (6)
SYMMETRY	SY	Parameter	5	95		Selects symmetry value.	SYMMETRY (7)
SYMMETRY?	SY?	Query				Request current symmetry value.	SYMMETRY (7)
SWEEPSTART	STA	Parameter	1E-3	20E6		Select sweep start frequency (Hz).	SWEEP MODE (26)
SWEEPSTART?	STA?	Query				Request current sweep start frequency.	SWEEP MODE (26)
SWEEPSTOP	STO	Parameter	1E-3	20E6		Select sweep stop frequency (Hz)	SWEEP MODE (26)
SWEEPSTOP?	STO?	Query				Requests current sweep stop frequency.	SWEEP MODE (26)
SWEEPTIME	STI	Parameter	100E-3	100		Select sweep time (seconds).	TIME (28)
SWEEPTIME?	STI?	Query				Requests current sweep time.	TIME (28)
SWEEPTRIGFREQ	STF	Parameter	10E-3	10		Selects sweep trigger frequency (Hz).	TRIG FREQ (27)
SWEEPTRIGFREQ?	STF?	Query				Requests current sweep trigger frequency (Hz).	TRIG FREQ (27)
SWEEPTYPE	STY	Parameter	0	1		Selects Lin or Log sweep.	LIN/LOG (26)
LINEAR	LI	Enumerated			0	Selects linear sweep.	
LOG	LO	Enumerated			1	Selects log sweep.	

Table 3-4. Model 95 GPIB Command Set

COMMAND	MIN UNIN.	COMMAND TYPE (¶ 3.4.2.1)	MIN	RANGE MAX	Value	DESCRIPTION	ASSOCIATED KEY
SWEEPTYPE?	STY?	Query				Requests current sweep type.	LIN/LOG (26)
SWEEPMODE	SMD	Parameter	0	4		Selects sweep modes.	SWEEP MODE (26)
START	SA	Enumerated			0	Sets generator to sweep start frequency	SWEEP MODE (26)
STOP	SO	Enumerated			1	Sets generator to sweep stop frequency.	SWEEP MODE (26)
CONTINUOUS	C	Enumerated			2	Sets generator to continuous sweep.	SWEEP MODE (26)
TRIGGERED	T	Enumerated			3	Sets generator to triggered sweep.	SWEEP MODE (26)
MANUAL	M	Enumerated			4	Sets generator to manual sweep.	SWEEP MODE (26)
SWEEPMODE?	SMD?	Query				Request current sweep mode.	SWEEP MODE (26)
SRQMASK	SQM	Parameter	0	255		Selects SRQ mask value	
SRQMASK?	SQM?	Query				Requests current SRQ mask value.	
SRQ?	SRQ?	Query				Requests current SRQ value.	
STATUSBYTE?	STB?	Query				Requests current status byte value	
SERIALNUMBERS?	SN?	Query				Requests units serial number.	
SMOOTHING	SM	Parameter	1	7		Selects digital filter value.	SMOOTH (17)
SMOOTHING?	SM?	Query				Requests current smoothing value.	SMOOTH (17)
STARTADDRESS	SRA	Parameter	0	8191		Selects Arb start address.	START ADDR (18)
STARTADDRESS?	SRA?	Query				Request current start address.	START ADDR (18)
STOPADDRESS	SPA	Parameter	0	8191		Selects Arb stop address.	STOP ADDR (19)
STOPADDRESS?	SPA?	Query				Requests current stop address.	STOP ADDR (19)
SYNCADDRESS	SYN	Parameter	0	8191		Selects Arb sync address.	SYNC ADDR (14)
SYNCADDRESS?	SYN?	Query				Request current sync address.	SYNC ADDR (14)

Table 3-4. Model 95 GPIB Command Set

COMMAND	MIN UNIN.	COMMAND TYPE (§ 3.4.2.1)	MIN	RANGE MAX	Value	DESCRIPTION	ASSOCIATED KEY
TRIGGERFREQ	TF	Parameter	1E-3	20E6		Select internal trigger frequency.	TRIG FREQ (27)
TRIGGERFREQ?	TF?	Query				Request current trigger frequency.	TRIG FREQ (27)
TRIGGER	TRG	Direct				Initiates a trigger.	MAN TRIG (25)
VERSION?	V?	Query				Request software version number.	

3.4.3 Universal and Addressed Commands

Universal and addressed (U/A) commands make most GPIB instruments perform generally accepted standard functions. Usually, universal commands control all the instruments on the GPIB bus, while addressed commands control individual instruments at specific addresses on the bus. The Model 95 accepts the following U/A commands:

Command	Type	Function
DCL	Universal	Device Clear
GET	Addressed	Group execute trigger
GTL	Addressed	Go to local
LLO	Universal	Local lockout command
SDC	Addressed	Selected device clear

Paragraph 3.4.4, Detailed Command Descriptions, discusses these U/A commands and selected Model 95 commands in detail.

Universal and Addressed Syntax

This manual uses generic names to identify the universal and addressed commands and the functions they perform. Individual controllers will use differently named commands to perform these same functions. See the manual for the controller being used to determine the actual command names and the syntax they require.

3.4.4 Detailed Command Descriptions

The following paragraphs describe in detail the unique Model 95 GPIB commands that perform functions not controlled by the front panel and the GPIB universal and addressed commands recognized by the Model 95. Use the following list to identify these specialized commands.

Command	Type	Description
DCL	Universal	Device Clear
GET	Address	Group Execute Trigger
GTL	Address	Go To Local
HELP?	Model 95	HELP?
LLO	Universal	Local Lock Out
MP?	Model 95	Main Parameters
SRQ?	Model 95	Service Request?
SQM	Model 95	Service Request Mask
SQM?	Model 95	Service Request Mask?
STB?	Model 95	Status Byte?
V?	Model 95	Version?

Front Panel Restrictions

The Model 95 limits the operator's use of the front panel with two levels of increasing restrictions as shown in table 3-5.

GPIB Control - The Model 95 switches to GPIB control when the instrument controller asserts the GPIB REN (remote enable) line and sends to the Model 95 its listen address. The controller command string WRITE @709:"- command string -" will automatically perform these two actions. The GPIB control restricts further front panel operation as described in table 3-5. The Model 95 will remain under the GPIB control until the operator presses the LOCAL key (32).

Table 3-5. Front Panel Restrictions

If Front Panel Operation Is Limited With ⇒		Nothing Control	GPIB Command	LLO
Then the Operator Can:	See the Screen Display?	Yes	Yes	Yes
	Display Parameters?	Yes	Yes	Yes
	Take Control Back From the GPIB?	Yes	Yes	No
	Change Parameters?	Yes	No	No

Local Lockout Command - All instruments on the bus recognize the universal local lock out command LLO; it cannot be directed to just one instrument. LLO restricts operation of the Model 95 front panel as described in table 3-5.

Go To Local Command - The Go To Local command GTL cancels the LLO command and returns the Model 95 front panel to full operator control. All instruments on the bus recognize the addressed command GTL; however, it must be sent to each instrument individually. GTL becomes effective on receipt; the Model 95 does not require that it be followed with another command.

Group Execute Trigger Command

The Group Execute Trigger command, GET, triggers whatever trigger function set up within the Model 95. All instruments on the bus recognize the GPIB addressed GET command. However, GET can be sent to just one instrument at a time. The Model 95 triggers the selected function immediately on receipt of the GET command.

HELP? Command

The HELP? command makes the Model 95 return a list of the Model 95's primary and secondary commands and their limits as a string to the controller. HELP? requires that a program be written to make the instrument

controller accept and print the returned list. The following program requests the list, accepts it, and sends it to a printer connected to the GPIB bus. Table 3-4 provides the same information as the list this program prints.

HELP Print Program

100	DIM A\$*255	Dimension String to 255 characters.
110	WRITE @709:"HELP?"	Write HELP to port 7, address 09.
120	READ @709:A\$	Read the String
130	IF A\$="0" THEN 170	If string is "0" jump to 170
140	PRINT A\$	Print the list
150	GO TO 120	
170	END	End Program

Main Parameters? Command

The MP? command makes the Model 95 return the current setting of the Model 95's main parameters as a string to the controller. The controller can save this string, then send it back to the Model 95 at a later time to restore the parameters to their previous values.

Device Clear Command

The device clear command DCL resets the Model 95 to the power-up conditions, but leave it in the remote (GPIB controlled) mode. All instruments on the bus recognize the GPIB universal command DCL (device clear). To reset everything on the bus, use DCL @7, where 7 specifies the GPIB bus port of the controller. To reset just one instrument, use DCL @709, where 09 specifies the instrument address. The Model 95 resets itself immediately when it receives either command.

Reset Command

The RESET command resets the Model 95 to default conditions. Table 3-1 lists the Model 95's default conditions.

Version? Command

The VERSION? command makes the Model 95 return the software version of the Model 95 EPROM as a string of characters. Version? requires a program to make the instrument controller use the returned string. The following program requests the version, accepts it, and writes the data to the screen.

Version? Print Program

10	CLEAR	Clear screen
20	WRITE @709:"V?"	Write VERSION? to port 7, address 09.
30	DIM VERSION\$*50	Dimension string to 50 characters.
40	READ @709:VERSION\$	Read returning string
50	PRINT VERSION\$	Print string to screen
60	END	End program

Running the above program will produce the following display:

```
WVTK 95 (VX.XX)
```

In this display, x gives the version number.

3.4.5 Service Requests - SRQ

The following paragraphs discusses service requests, describes the commands associated with them, and lists the service request messages the Model 95 generates. The Model 95 can set the SRQ line whenever a programming error occurs, a hardware error occurs, an event is completed, Phase lock changes state, or a Calibration message is displayed.

SRQ Concepts

What Does the Service Request Tell the Controller?

The Model 95 service request tells the controller that the Model 95 wants attention by asserting the SRQ line of the GPIB bus. Because any instrument on the bus can assert this line, the controller must read the status byte of each instrument in turn to determine which one requested attention.

What Does the Status Byte Tell the Controller?

The Model 95 uses five of the eight bits in its status byte. One tells the controller if the Model 95 requested service. The others indicate the type or types of messages (programming error, event, Phase Lock state, or Calibration messages) the Model 95 wants to send. Figure 3-6 shows the format of the Model 95 status byte. If the controller wants to know the specific message within the category, it must read the Model 95's SRQ buffer.

What Does the SRQ Buffer Tell the Controller?

The Model 95 SRQ buffer stores the programming error, event complete, Phase Lock state, and Calibration messages until the controller can read them. Tables 3-6 through 3-9 list all of the SRQ messages.

SRQ COMMANDS

The following paragraphs discuss the commands related to the service request mask, the status byte and the service request messages.

SRQ Mask Command

The SQM command makes the Model 95 selectively ignore one or more of the three types of conditions that make it produce service requests. For example, if programming errors were masked out, the Model 95 would not load messages for specific programming errors into the SRQ buffers and it would not set the PE and service request bits in the status byte. Figure 3-9 shows the positions and the corresponding decimal mask values required to block out PE, CM, PL, and EV messages. The SRQ mask is reset to SRQ mask #1 (programming error only) at power on. It is not changed by "RESET"

SRQ Mask? Command

The SQM? command makes the Model 95 return the current mask setting to the controller. The Model 95 sends the SRQ mask setting as the character string SRQMASK#, where # gives the decimal equivalent of the binary mask bits. To use SRQMASK?, write a program that first asks the Model 95 to send the mask, then tells the controller how to receive and process the returning string.

Status Byte? Command

The STB? command makes the Model 95 send its current status byte to the controller over the GPIB bus. The Model 95 sends its status byte as a string of characters with the format STB=##, where ## gives the decimal equivalent of the status byte. STatusByte? reads, but does not reset, the status byte of the Model 95. To use STatusByte?, write a program asking the Model 95 to send the status byte, then tell the controller how to receive and process the returning string.

SRQ? Command

The SRQ? command makes the Model 95 send the contents of the SRQ buffer to the controller over the GPIB bus. The Model 95 sends its SRQ buffer contents as a string of characters with the format SRQ = MESSAGES, where MESSAGES represents a string of messages. Reading the SRQ buffer empties it. To use SRQ?, write a program that first asks the Model 95 to send the SRQ buffer messages, then tells the controller how to receive and process them.

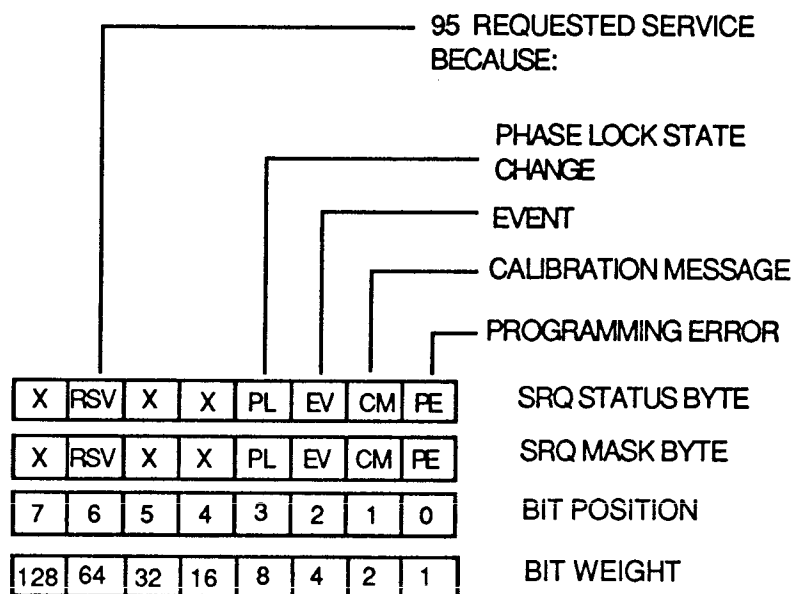

Figure 3-9. Model 95 Status Byte and SRQ Mask

SRQ MESSAGES

SRQ Message Format

The Model 95 puts messages in the SRQ buffer in this general format:

SRQ=/PE:n Description//CM:n Description//EV:n Description//PL:n Description/

Slashes (/) enclose each message. PE identifies a programming error message, CM identifies the calibration error message, EV an event complete message, and PL indicated a phase lock state change. "n" identifies a specific message within the type. This fixed format header allows a computer to easily parse (decode) the message. "Description" describes the error in English for the benefit of human readers. Table 3-6. lists all the SRQ programming error messages, table 3-7 lists all the SRQ calibration error messages, table 3-8 lists all the SRQ event error messages, and table 3-9 lists all the SRQ phase lock state change error messages.

3.4.6 Displaying Messages

The Model 95 can accept messages from the GPIB bus and display them on the front panel display. Use this feature to give instructions to an operator or to display information.

.c.Message Format

Send messages in this format:

WRITE @709:" 'TEXT' "

The standard double quotes (") identify the command string. The single quotes (') identify the contents as a message rather than commands. Messages do not require an Execute command.

Message Size

The screen will allow a maximum message size of four lines of 16 characters. The Model 95 ignores any characters beyond these limits.

Erasing Messages

Press any key or send another GPIB command string to return to normal Model 95 displays. To erase the previous message, send a new message.

3.4.7 Selftest Query Responses

When the Model 95 receives a SELFTEST? command, it sends the total decimal value of selftest error that occurred at power on. Refer to table 3-10.

Table 3-6. SRQ Programming Error Messages

Message	Description																														
/PE:0 < defective command string > /	The Model 95 did not recognize the command it received. A <defective command string > is whatever erroneous data the Model 95 received over the bus.																														
/PE:1 < parameter header > /	This is a limit error. An attempt was made to set a parameter to an illegal value. A <parameter header> is the maximum header string; that is "FREQUENCY" or "AMPLITUDE".																														
/PE:2:< param# >:< param# > param name >-< param name >	This is a setting conflict error. This service request will < occur after an execute command if there are CONFLICT/ conflicting settings. It will only flag the first conflict that it finds. <table border="0"> <tr> <td style="padding-right: 20px;">< param# ></td> <td>< param name ></td> </tr> <tr> <td>1</td> <td>FREQUENCY</td> </tr> <tr> <td>2</td> <td>AMPLITUDE</td> </tr> <tr> <td>3</td> <td>OFFSET</td> </tr> <tr> <td>4</td> <td>SYMMETRY</td> </tr> <tr> <td>5</td> <td>PHASE</td> </tr> <tr> <td>6</td> <td>FUNCTION</td> </tr> <tr> <td>7</td> <td>MODULATION</td> </tr> <tr> <td>8</td> <td>EXTLOCK</td> </tr> <tr> <td>9</td> <td>OUTPUT</td> </tr> <tr> <td>10</td> <td>SWP START</td> </tr> <tr> <td>11</td> <td>SWP STOP</td> </tr> <tr> <td>12</td> <td>SWP TIME</td> </tr> <tr> <td>13</td> <td>AMPLITUDE-OFFSET</td> </tr> <tr> <td>14</td> <td>RANGE LOCK</td> </tr> </table>	< param# >	< param name >	1	FREQUENCY	2	AMPLITUDE	3	OFFSET	4	SYMMETRY	5	PHASE	6	FUNCTION	7	MODULATION	8	EXTLOCK	9	OUTPUT	10	SWP START	11	SWP STOP	12	SWP TIME	13	AMPLITUDE-OFFSET	14	RANGE LOCK
< param# >	< param name >																														
1	FREQUENCY																														
2	AMPLITUDE																														
3	OFFSET																														
4	SYMMETRY																														
5	PHASE																														
6	FUNCTION																														
7	MODULATION																														
8	EXTLOCK																														
9	OUTPUT																														
10	SWP START																														
11	SWP STOP																														
12	SWP TIME																														
13	AMPLITUDE-OFFSET																														
14	RANGE LOCK																														

Table 3-7. SRQ Calibration Messages

Message	Description
/CM:0 < cal index >< cal name > /	This is a failure to complete an AutoCal step. AutoCal< cal index > is a number associated with the calibration parameter that failed adjustment. < cal name > identifies a name associated with the failed calibration parameter .

Table 3-7. SRQ Calibration Messages (Continued)

Message	Description
/CM:1 WAIT < time > MIN/	AutoCal was attempted before the required 20 minute warm-up. < time > is the time (in minutes) remaining before an AutoCal can be performed.

Table 3-8. SRQ Event Complete Error Messages

Message	Description
/EV:0 AUTOCALIBRATION COMPLETE/	AutoCal was completed.
/EV:1 EXECUTE COMPLETE/	Execute was complete. After an execute command, the Model 95 will send either this service request or a PE:2 (assuming both PE and EV SRQ's are enabled by the SRQ mask).
/EV:2 SWEEP COMPLETE/	Sweep was completed.
/EV:3 BURST COMPLETE/	Burst count was completed.

Table 3-9. SRQ Phase Lock State Change Error Messages

Message	Description
/PL:0 PLL UNLOCKED/	The phase lock loop has changed from an unlocked state to a locked state.
/PL:0 PLL LOCKED/	The phase lock loop has changed from a locked state to an unlocked state.

Table 3-10. Selftest Query Error Messages

Message (Decimal Value)	Description
128	RAM Lost Battery Backup - Calibration Corrupted
64	Backup Arb RAM Failure
8	Active Arb RAM Failure
4, 2, and 1	Main RAM Failure

3.5 OPERATION

Paragraph 3.5 ties together the descriptions of the controls and connectors (paragraph 3.2), as well as GPIB commands (paragraph 3.4), into sets of instructions on performing various operations using the Model 95. To quickly get familiar with the Model 95, perform the Initial Checkout Procedure - paragraph 2.3.5.

The operations described in this paragraph are listed below.

Basic Instrument Setup	paragraph 3.5.3
Variable (Time) Symmetry	paragraph 3.5.4
Phase Lock and Phase Shift	paragraph 3.5.5
Continuous Arb Waveform	paragraph 3.5.6
Triggered Mode	paragraph 3.5.7
Gated Mode	paragraph 3.5.8
Burst Mode	paragraph 3.5.9
Amplitude Modulation	paragraph 3.5.10
Suppressed Carrier Modulation	paragraph 3.5.11
Frequency Modulation	paragraph 3.5.12
Voltage Controlled Generator VCG	paragraph 3.5.13
Continuous Sweep	paragraph 3.5.14
Triggered Sweep	paragraph 3.5.15
Manual Sweep	paragraph 3.5.16
Storing and Recalling Settings	paragraph 3.5.17
Arb Waveforms and Arb Editing	paragraphs 3.5.18 and 3.5.19

Before beginning the operation of the Model 95, review the general information in paragraphs 3.5.1 and 3.5.2.

3.5.1 Instrument Setup

Before using the Model 95, the primary power input must be connected and outputs properly terminated.

Primary Power

Before using the Model 95 verify the voltage selector and fuse (D) are set to match the primary power source; see paragraph 2.4.1.

Output Terminations

For proper output levels and responses, each output connector used must be properly terminated. Termination requires a correct combination of "load" or terminating impedance and the cable impedance that matches the Model 95's source impedance. Most output (Sweep Out, Sync Out, etc.) have fixed outputs impedances, listed in table 3-11. The Mode 95's two function outputs (Balanced and Unbalanced) have selectable source impedances; also see table 3-11. The balanced and unbalanced output each requires different interconnection techniques. Figure 3-11 illustrates these two output interconnections.

Unbalanced Output. For the unbalanced (single ended) output, connect the output from the Model 95 to the receiving instrument using a single cable or coax and a single termination impedance; see figure 3-7 - Unbalanced Output. In figure 3-7, R_S represents the unit's selected output impedance. Proper output termination requires the cable and impedance both matches the source impedance. The receiving instrument's input impedance must be greater than the source impedance.

Balanced Output. Balanced output requires a different technique, as shown in figure 3-7 - Balanced Output. The primary use for balance outputs would be audio and telecommunication devices when driving devices with differential inputs. To connect the Model 95's Balanced Output to the receiving instrument, use a twisted pair and terminating impedance to matches the selected source impedance. The example shown in figure 3-7 Balanced Output uses the receiving instrument's balanced input for termination. Appendix B illustrates another technique that connect the Model 95 to a dual channel oscilloscope.

Table 3-11. Model 95 Input/Output Impedances

Connector	Impedance	Comments
UNBALANCED (35)	50Ω, 75Ω, or 600Ω	Use SELECT (36)
BALANCED (38)	135Ω or 600Ω	Use SELECT (36)
SWEEP OUT (29)	600Ω	
MOD IN (30)	10 kΩ	
SYNC OUT (13)	50Ω TTL	
TRIG/FREQ IN (12)	10 kΩ	
REF IN (A)	>1kΩ	
REF OUT (B)	50Ω	
Z-AXIS (C)	50Ω	

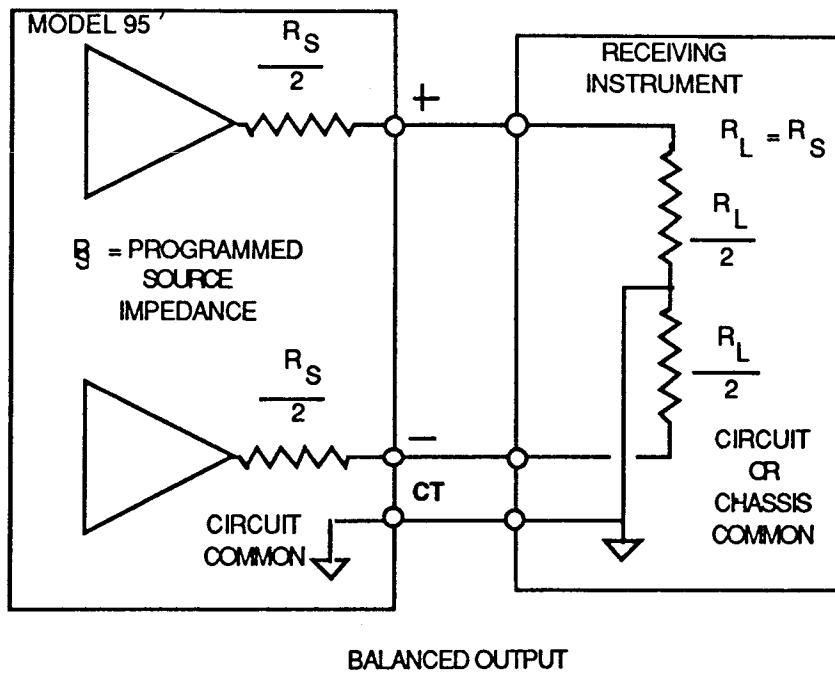
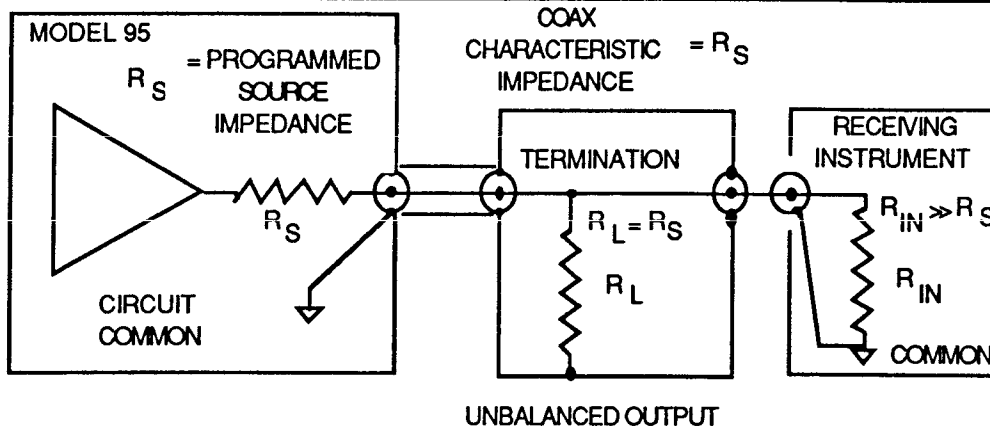

Figure 3-7. Output Terminations

3.5.2 Power On and Reset

Press the POWER key (1) to turn on or off the Model 95. Turning on the power, returns the Model 95 to the last instrument setup, except the output (Balanced or Unbalanced) will be off. The last selected output impedance indicator (37) will flash. Use the ON/OFF key (36) to turn on the output.

Setting a Single Parameter to Its Default Value

From the front panel use the PARAMETER RESET key (2) to reset the displayed parameter to its default value. Refer to table 3-1, key item 2, "Model 95 Default Conditions".

Over the GPIB send the command PARAMETERRESET or PR to reset the last transmitted value to its default value.

Setting All Parameter To Their Default Values

From the front panel use the RESET ALL key (2) (SHIFT key and RESET ALL key) to reset all Model 95 parameters to their default values.

Over the GPIB send the command RESET or R to reset all Model 95 parameters except the GPIB address.

3.5.3 Basic Generator Setup

The basic Model 95 produces continuous waveforms of all functions at a single frequency with a fixed amplitude. The frequency can be between 1mHz and 20 MHz. Between 20Hz and 20MHz the Model 95's internal synthesizer controls the frequency accuracy and stability (± 10 ppm). The frequency accuracy decreases to $\pm 3\%$ below 20Hz.

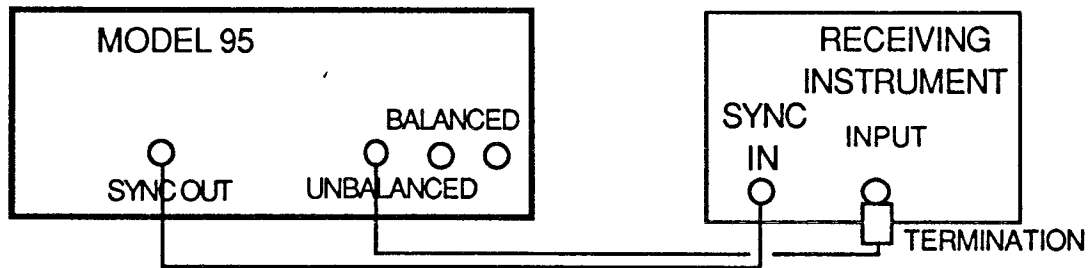

Figure 3-8. Continuous Operation Interconnection

Paragraph 3.5.3.1 describes the steps required to set up the Model 95 for continuous outputs using the front panel. Paragraph 3.5.3.2 describes the steps required to setup the Model 95 for continuous output using a GPIB controller. Figure 3-8 shows a typical instrument setup for continuous operation.

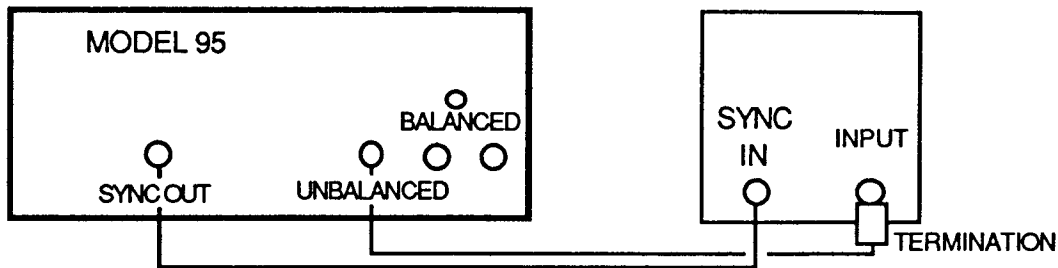

Figure 3-8. Continuous Operation Interconnection

3.5.3.1 Local Operation

After power on (paragraph 3.5.2), use the following steps to setup the Model 95 for continuous output.

1. **Select the Mode.** Use the MODE key (22) to step to the continuous mode (CONT indicator lit (23)). To step backwards through the modes, press the SHIFT key and then hold down the MODE key. Release the MODE key when the indicator lights to select the mode.
2. **Select the Function.** Use the FUNCTION key (15) to select the desired function: sine triangle, or square; Arb 1, Arb 2, Arb 3, or Arb 4 are covered in paragraph 3.5.6.1. For dc output see step 5, "DC Function". Holding down the function key causes the unit to cycle through the functions. Release the key to stop and select the function. The appropriate function indicator (16) will be lit.

To step backwards through the functions, press the SHIFT key and then hold down the FUNCTION key. Release the FUNCTION key when the indicator lights to select the function.

3. **Select the Frequency.** Press the FREQ/SAMP key (4) to display the frequency. Use the keypad (39) or the knob (41), if enabled (ENABLE indicator (40) lit), to change the frequency. The knob increments or decrements the value starting from the flashing digit (knob key (39)) and automatically enters the new value. When using the keypad, enter values as actual numbers (5000) or exponential notation (5E3), press the ENTER key to accept the new value. Frequency range for the function generator is
 - 1mHz to 20.00 MHz (frequency selected)
 - 1000.0s to 50 ns (period selected)

Use the frequency's UNITS key (4) to select the unit of measure: frequency or period for the function generator (sine, triangle, and square). See paragraph 3.5.6.1 for Arb operation.

Limitations:

- Maximum frequency derates above 2MHz when symmetry not 50%
- Maximum frequency limited to 1MHz when 135Ω and 600Ω Balanced selected.
- Minimum frequency limited to 20Hz for internal phase lock (accuracy ±10ppm)

4. **Set up the Amplitude.** Use the AMPLITUDE key (5) to display the amplitude. Use the keypad (39) or the knob (41), if enabled (ENABLE indicator (40) lit), to change the amplitude. The knob increments or decrements the value starting from the flashing digit (KNOB key (39)) and automatically enters the new value. When using the keypad, enter values as actual number (10) or exponential notation (1E1), press the ENTER key to accept the new value. Amplitude range is on the function selected and the amplitude units as shown below.

	Sine	Triangle	Square
Vpp	1mVpp - 15Vpp	1mVpp - 15 Vpp	1mVpp - 15Vpp
Vp	0.6mVp - 7.5Vp	0.6mVp - 7.5Vp	0.6mVp - 7.5Vp
Vrms	0.4mVrms - 5.3Vrms	0.3mVrms - 4.33Vrms	0.5mVrms - 7.5Vrms
dBm	-56 dBm - +27.5 dBm	- 57.8dBm - +25.7dBm	- 53dBm - +30.5dBm

Use the Amplitude's UNITS key (5) to select the unit of measure: Vpp, Vp, Vrms, or dBm.

Limitations:

Amplitude limited by Offset values ($\text{Offset} + V_p \leq 7.5V$).

Amplitude limited to half of maximum level when AM selected.

Vpp and Vp only allowed when the dc offset is not 0Vdc, symmetry is not 50%, or Arb waveforms are selected.

5. **Set up the Offset.** Use the OFFSET key (7) to display the dc offset level. Offset is the waveform reference level relative to 0Vdc; see figure 3-9. Use the keypad (39) or the knob (41), if enabled (ENABLE indicator (40) lit), to change the offset. The knob increments or decrements the value starting from the flashing digit (Knob key (39)) and automatically enters the new value. When using the keypad, enter values as actual number (.01) or exponential notation (10 E -3), press the ENTER key to accept the new value. Offset values range from +7.500V to -7.500V.

Limitations:

Offset limited by the peak amplitude value ($\text{Offset} + V_p \leq 7.5V$).

Offset fixed at 0Vdc when BAL (Balanced output) selected.

Offset range limited to half of the maximum offset when AM selected.

DC Function. In dc function, the Model 95 produces a dc voltage. The OFFSET key when used with the keypad and knob controls the output polarity and level.

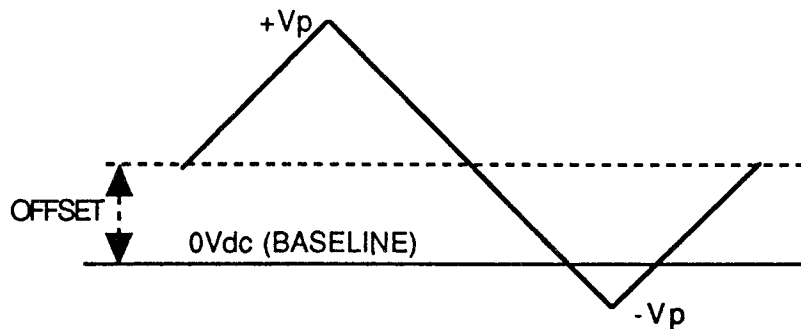

Figure 3-9. Offset Waveform Example

6. **Turn ON/OFF the Output and Select the Output Impedance.**

Use the ON/OFF key (36) to turn on or off the output. If the output is turned off, it will be at power on, the impedance indicator flashes, and pressing the ON/OFF key turns on the output and returns the Model 95 to the last selected output and impedance. The impedance indicator remains on.

Use the SELECT key (36) to choose the output connector (balanced or unbalanced) and output impedance (50Ω, 75Ω, 135Ω, and 600Ω). Pressing the SHIFT key and then the SELECT key increments through the impedances and outputs in the following order:

50Ω Unbalanced Output

75Ω Unbalanced Output

600Ω Unbalanced Output (frequency limited to 1MHz)

600Ω Balanced Output (frequency limited to 1MHz)

135Ω Balanced Output (frequency limited to 1MHz)

Also after pressing the SHIFT key, hold down the SELECT key to auto-increments through the list in the same order as above. Release the key to select the impedance and output; the indicators remain lit.

Sync Output The Sync Output pulse will be in phase with the Square wave, but will be 90° out of phase with the Sine and Triangle waves.

NOTE

When connecting the Model 95 output connector to a load, use a cable with the correct impedance for the output selected. Balanced ct connector is internally connected to the shield of all the other Model 95 BNC connectors. When connecting to external equipment, whose connector shields are at chassis ground, a ground loop will be formed that will adversely affect the Balanced output signal.

3.5.3.2 GPIB Operation

After instrument setup (paragraph 3.5.1) and power on (paragraph 3.5.2), use the following steps to set up the Model 95 for continuous output. The examples shown are terminated with a semicolon (;) which indicates the command is part of a string. If only the one command is sent to the Model 95, replace the semicolon with EXECUTE or EX.

1. **Select the Mode.** Send the Mode command followed by the continuous parameter.

Mode Commands: MODE or MO.

Continuous Parameters: C or 0.

The commands and parameters can be mixed; "MODE 0;" , "MO 0;" , "MODE C;" , or "MO C;" will select the continuous mode.

2. **Select the Function.** Send the Function command followed by the parameter.

Function Commands: FUNCTION or FU.

Sine Parameters: SINE, SI, or 0

Triangle Parameter: TRIANGLE, T, or 1

Square Parameter: SQUARE, SQ, or 2.

DC Parameter: DC, D, or 3

Arb parameters are covered in paragraph 3.5.6.2

The commands and parameters can be mixed. For example, sending either the string "FUNCTION SINE;" or "FU 0;" will select the sine function.

3. **Select the Frequency.** Send the Frequency command followed by the parameter.

Frequency Commands: FREQUENCY or FR.

Frequency Parameters: Values in Hz between 2E-3 and 20E6. Values can be entered in any format. For example 2kHz can be entered as 2000, 2E3, 20E2, etc.

For example, sending either "FREQUENCY 1E6;" or "FR 1000000;" will select 1MHz.

4. **Select the Amplitude.** Send the Amplitude command followed by the parameter.
Amplitude Commands: AMPLITUDE or AM.
Amplitude Parameters: Values in Vpp between 1E-3 and 15. Values can be entered in any format. For example 10Vpp can be entered as 10, 1E1, 10E0, etc.
For example, sending either "AMPLITUDE 12;" or "AM 1.2E1;" will select 12Vpp amplitude.

5. **Select the Offset.** Send the Offset command followed by the parameter.
Offset Commands: OFFSET or OF.
Offset Parameters: Values in Vdc between -7.5 and 7.5.
For example, sending either "OFFSET -3;" or "OF -3;" offsets the waveform by -3Vdc.

DC Output If the dc function is selected ("FU DC;"), send the DC Output command and parameters to control the dc output voltage.

DC Output Command: DCOUT or DC,

DC Output Parameter (Vdc): Values can be between -7.5 and +7.5. Values can be entered in any format. For example 2Vdc can be entered as 2 or 2E0.

6. **Turn On or Off the Output.** Send the Output enable command followed by the parameter.
Output Commands: OUTPUT or OP.
Parameters: 1 turns the output on, and 0 turns the output off.
For example, sending OP 1 will turn the output on.

7. **Select and Output and Output Impedance.** Send the Output Select command followed by the parameter.
Output Select Commands: OUTSELECT or OS.
50Ω Unbalanced Output Parameter: U50 or 0.
75Ω Unbalanced Output Parameter U75 or 1.
600Ω Unbalanced Output Parameter: U600 or 2.
600Ω Balanced Output Parameter: B600 or 3
135Ω Balanced Output Parameter: B135 or 4.
For example, sending either "OUTSELECT 0;" or "OS U50;" selects the unbalanced 50Ω output.

8. **Terminate the command string.** Send the EXECUTE command "EX" to terminate the command string. The Model 95 also accepts the FASTEXECUTE command (FE) which executes the command string significantly faster than the EXECUTE command. However, FASTEXECUTE only works when the frequency, amplitude, offset, or dc offset is changed, and the string is executed without any error checking.

Example

The following example uses a GPIB command string to setup the Model 95 to produce a 2kHz triangle wave, 1.5Vpp at the unbalanced output with 50Ω impedance.

"MODE C; FU T; FR 2E3; AM 1.5; OP 1; OS U50;EX"

3.5.4 Variable (Time) Symmetry

Variable symmetry allows the duty cycle of the three standard function (sine, triangle, and square) to be varied from 5% to 95% in 1% increments (≤ 2 MHz). Use variable symmetry with square waves to produce pulses. Use variable symmetry with triangles to produce ramps. Between 2MHz and 20MHz the minimum and maximum symmetry values decrease linearly to 50% at 20MHz; see figure 3-10. For example, at 10 MHz, the symmetry range is decreased to 25% to 75%. The symmetry of the Sync Output will track the function outputs.

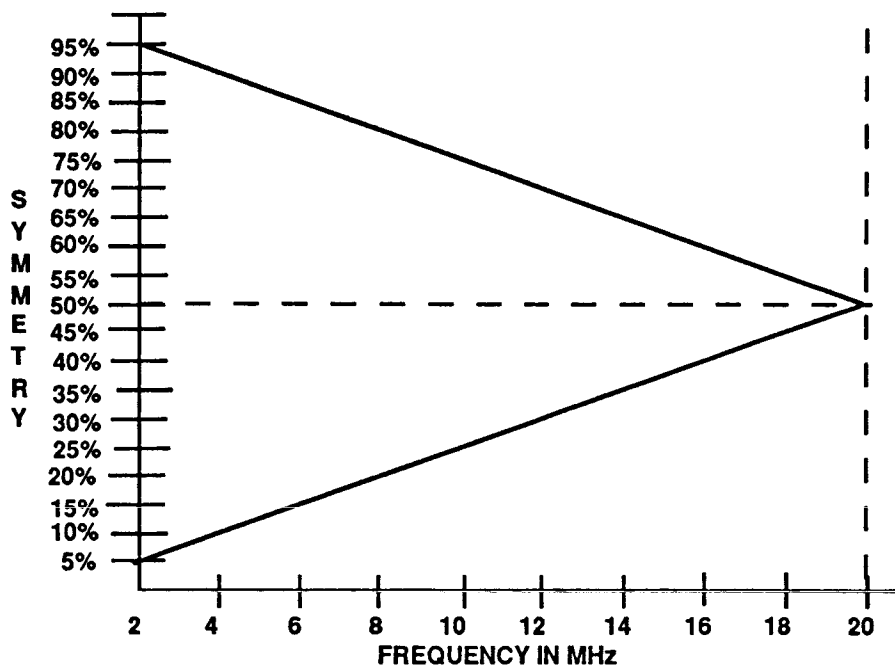

Figure 3-10. 2MHz to 20 MHz Symmetry

3.5.4.1 Local Operation

After power on (paragraph 3.5.2), set up the Model 95 as described in paragraph 3.5.3.1.

1. **Select Symmetry.** Press the SHIFT key (31) and then the SYMMETRY key (7) to display the current symmetry value.
2. **Change the Symmetry.** Use the keypad (39) or knob (41), if enabled (ENABLE indicator (40) lit), to change the symmetry. The knob increments or decrements the value and automatically enters the new value. When using the keypad, enter the actual value. Symmetry values are 5% to 95% in 1% increments unless limited by frequency; see figure 3-10.

3.5.4.2 GPIB Operation

After power on (paragraph 3.5.2), setup the Model 95 as described in paragraph 3.5.3.2. Except add the symmetry command and parameter to the command string.

Symmetry Commands: SYMMETRY or SY

Symmetry Parameters: values in % between 5 and 95.

Send the EXECUTE command "EX" to terminate the command string.

Example

The following example uses a GPIB command string to setup the Model 95 to produce a 2kHz triangle wave at 75% duty cycle, 1.5Vpp at the unbalanced output with 50Ω impedance.

"MODE C; FU T; FR 2E3; SY 75; A 1.5; OP ON; OS U50;EX"

3.5.5 Phase Lock and Phase Shift

Phase lock allows an external or internal frequency source to control the accuracy and stability of the Model 95. Using the internal source (synthesizer) improves the Model 95 frequency accuracy to ± 10 ppm. Option 001 increases the accuracy to ± 1 ppm. When an external source is connected, the Model 95 measures the frequency

of the source, sets its frequency to match the source, and automatically phase locks itself to the source. Also, when an external source is used, the phase of the Model 95's output can be shifted relative to the source.

The Model 95 phase lock (internal and external source) limits:

Frequency – 20Hz to 20 MHz.

Mode – Continuous, SCM, or AM.

Symmetry – 50% duty cycle only.

Amplitude (external source) – 600 mVpp to 30Vpp

3.5.5.1 Internal Phase Lock

Local Operation.

1. **Set up the Model 95.** Set up the Model 95 as described in paragraph 3.5.3.1.
2. **Select the Internal Source.** To select the internal source, (default) press the TRG/LOCK SOURCE key (11) to display the internal reference frequency. Each time this key is pressed, the reference source toggles between internal and external.
3. **Phase Lock Indicators.** There are two front panel indicators used with phase lock: UNLOCK (9) and EXT (10).
 - If the UNLOCK indicator is off, the unit is phase locked to the selected source.
 - If the UNLOCK indicator is flashing, the internal source is faulty, or the external source is not connected.
 - If the UNLOCK indicator is on steady, the instrument setup will not allow phase locking.
 - If the EXT indicator is off, internal source is selected.
 - If the EXT indicator is on, the external source is selected.

GPIB Operation

1. **Set up the Model 95.** Set up the Model 95 as described in paragraph 3.5.3.2. Except add the source command to the string.
2. **Select the Phase Lock Source.** To select the internal source, send the Source command followed by the parameter.
 - Source Command : SOURCE or SRC
 - Internal Source Parameter: INTERNAL, I, or 0.The UNLOCK and EXT indicators respond the same as in local operation

Example

The following example uses a GPIB command string to setup the Model 95 to produce a 2kHz triangle wave, 1.5Vpp at the unbalanced output with 50Ω impedance phase locked to the internal reference. "SRC I" does not need to be included because it is a default.

"MODE C; FU T; FR 2E3; SRC I; AM 1.5; OP 1; OS U50;EX"

3.5.5.2 External Phase Lock

To set up the Model 95 for external phase lock, refer to Figure 3-11.

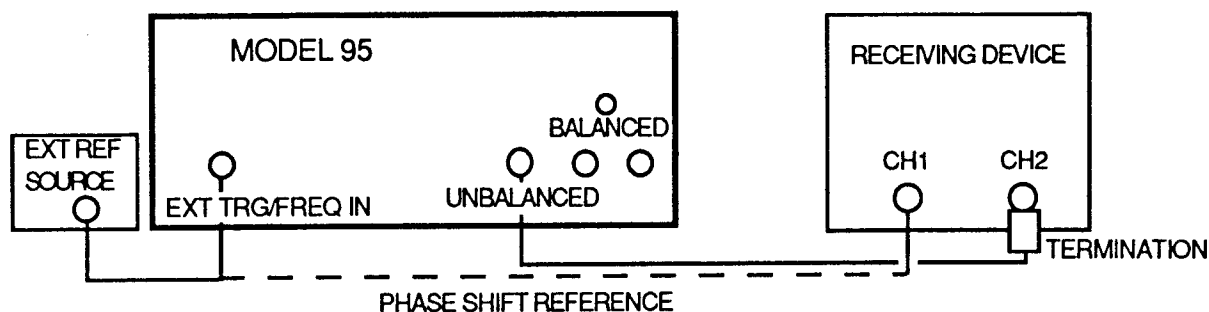

Figure 3-11. External Phase Lock Setup

Local Operation.

1. **Set up the Model 95.** Set up the Model 95 as described in paragraph 3.5.3.1.
2. **Select External Source.** To select the external source, press the TRG/LOCK SOURCE key (11) to display the external reference frequency (if connected) "EXTLOCK XXXXHZ". Each time this key is pressed, the reference source toggles between internal and external. The Model 95 measures the frequency of the external source (see external source limits), sets its generator to the measured frequency, and phase locks the generators together

Phase Lock Indicators. There are two front panel indicators used with phase lock: UNLOCK (9) and EXT (10).

If the UNLOCK indicator is off, the unit is phase locked to the selected source.

If the UNLOCK indicator is flashing, the internal reference is faulty, or the external reference is not connected.

If the UNLOCK indicator is on steady, the instrument setup will not allow phase locking.

If the EXT indicator is off, internal reference source is selected.

If the EXT indicator is on, the external reference source is selected.

3. **External Source.** Connect the external source to the TRIG/FREQ IN connector (12). If the external source is within the limits, the Model 95 displays external frequency when EXTLOC is selected - TRG/LOCK SOURCE key (11). The EXT indicator also lights

GPIB Operation

1. **Set up the Model 95.** Set up the Model 95 as described in paragraph 3.5.3.2.
2. **Select the External Source.** To select the external reference, send the Source command followed by the parameter.
 SOURCE Command: SOURCE or SRC
 Source Parameter: EXTERNAL, EX, or 1.
 The UNLOCK and EXT indicators respond the same as in local operation.
3. **External Source.** Connect the external source to the TRIG/FREQ IN connector (12). The EXT indicator also lights if the source is within the limits.

Example

The following example uses a GPIB command string to setup the Model 95 to produce a 2kHz triangle wave, 1.5Vpp at the unbalanced output with 50Ω impedance phase locked to a 2kHz external reference.

"MODE C; FU T; FR 2E3; SRC E; AM 1.5; OP 1; OS U50;EX"

3.5.5.3 Phase Shift

When connected to an external source, the Model 95 permits the phase of its output waveform to be shifted $\pm 180^\circ$ or ± 3.14 ($\pm\pi$) radians relative to the external reference. See figure 3-11 for instrument setup.

Local Operation

1. **Set up the Model 95.** Set up the Model 95 for external phase lock as described in paragraph 3.5.5.2-Local Operation. Use the signal at the TRIG/FREQ IN connector (12) as the phase reference.
2. **Select the Phase Shift.** Press the PHASE key (8) to display the current phase shift. Use the keypad (39) or knob (41), if enabled (ENABLE indicator (40) lit), to change the phase. Use the KNOB key (39) to activate the Knob. The knob increments or decrements the value and automatically enters the new value. When using the keypad, enter values as actual number (120) or exponential notation (12E1), press the ENTER key to accept the new value.
3. **Selecting Alternate Units.** Model 95 allows the phase shift in degrees or radians. Press the SHIFT key and then the Phase's UNITS key (4) to step between degrees ($^\circ$) and radians (π). After the SHIFT-UNITS key combination the knob may be used to toggle between the units.

GPIB Operation

1. **Set up the Model 95.** Set up the Model 95 for external phase lock as described in paragraph 3.5.5.2 GPIB Operation. Use the signal at the TRIG/FREQ IN connector (12) as the phase reference.
2. **Select the Phase Shift.** Send the phase shift command followed by the parameter.
Phase Shift Commands: PHASE or P.
Phase Shift Parameters: Values in degrees between -180 and $+180$. Values can be entered in any format. For example 120° can be entered as 120, 1.2E2, 12E1, etc. For example, sending either "PHASE -120 ;" or "P $-12E1$;" selects -120° phase shift.

Example

The following example uses a GPIB command string to setup the Model 95 to produce a 2kHz triangle wave, 1.5Vpp at the unbalanced output with 50Ω impedance phase locked to a 2kHz external reference.

Phase shift is -120°

"MODE C; FU T; FR 2E3; SRC E; P $-12E1$; AM 1.5; OP 1; OS U50;EX"

3.5.6 Continuous Arbitrary Waveform

Arb waveforms are user defined waveforms stored in the Model 95 as functions Arb 1, Arb 2, Arb 3, and Arb 4. The Model 95 stores as part of the Arb waveform the start address, the stop address, and the sync address. This paragraph does not cover creating or editing of Arb waveforms; see paragraph 3.5.18. Figure 3-8 shows a typical instrument setup for operation.

3.5.6.1 Local Operation

After power on (paragraph 3.5.2), use the following steps to setup the Model 95 for continuous Arb waveform output.

1. **Select the Mode.** Use the MODE key (22) to step to the continuous mode (CONT indicator lit (23)). To step backwards through the modes, press the SHIFT key and then hold down the MODE key. Release the MODE key when the indicator lights to select the mode.
2. **Select the Function.** Use the FUNCTION key (15) to select the desired Arb function: Arb 1, Arb 2, Arb 3, or Arb 4. The appropriate function indicator (16) will be lit. To step backwards through the

functions, press the SHIFT key and then hold down the FUNCTION key. Release the FUNCTION key when the indicator lights to select the function.

3. **Select the Arb Clock Rate.** Use the **FREQ/SAMP** key (4) to display the Arb clock rate. Use the keypad (39) or the knob (41), if enabled (ENABLE indicator (40) lit), to change the rate. Use the **KNOB** key (39) to activate the Knob. The knob increments or decrements the value starting from the flashing digit (Knob key (39)) and automatically enters the new value. When using the keypad, enter values as actual number (5000) or exponential notation (5E3), press the **ENTER** key to accept the new value.

Press the **SHIFT** and then frequency's **UNITS** key (4) to select the unit of measure: sample period, sample frequency, waveform period, or waveform rate for the Arb generator (Arb 1, Arb 2, Arb 3, and Arb 4). After the **SHIFT-UNITS** key combination the knob may be used to toggle between the units.

Sample Frequency clocks each point of the Arb waveform; sample period ranges from 0.001Hz to 20 MHz.

Sample Period clocks each point of the Arb waveform; sample period ranges from 1000.0s to 50ns.

Waveform Frequency is the total frequency of the Arb waveform. The maximum block frequency depends upon the number of points in the waveform:

$$\text{Waveform Frequency} = \text{Sample Frequency} \times (\text{stop address} - \text{start address}).$$

For example, if the waveform consists of 1000 points, the maximum block frequency will be 20 kHz.

Waveform Period is the repetition rate of the Arb waveform. The maximum block period depends upon the number of points in the waveform:

$$\text{Waveform Period} = \text{Sample Period} \times (\text{stop address} - \text{start address}).$$

For example, if the waveform consists of 1000 points, the maximum block period will be 0.5ms.

4. **Output Setup.** Set up the amplitude, offset, output, and output impedance as described in paragraph 3.5.3.1.

Remember, this paragraph only covers how to setup the Model 95's Arb waveforms; paragraph 3.5.18 describes how to create and edit the Arb waveforms.

3.5.6.2 GPIB Operation

After instrument setup (paragraph 3.5.1) and power on (paragraph 3.5.2), use the following steps to setup the Model 95 for continuous Arbitrary waveform output. The examples shown are terminated with a semicolon (;) which indicates the command is part of a string. If only the one command is sent to the Model 95, replace the semicolon with EXECUTE or EX.

1. **Select the Mode.** Send the Mode command followed by the continuous parameter.

Mode Commands: MODE or MO

Continuous Parameters: C or 0.

The commands and parameters can be mixed; "MODE 0;", "MO 0;", "MODE C;", or "MO C;" will select the continuous mode.

2. **Select the Function.** Send the Function command followed by the parameter.

Function Commands: FUNCTION or FU.

Arb Waveform 1 Parameter: ARBWAVEFORM1, AW1, or 4

Arb Waveform 2 Parameter: ARBWAVEFORM2, AW2 or 5

Arb Waveform 3 Parameter: ARBWAVEFORM3, AW3 or 6

Arb Waveform 4 Parameter: ARBWAVEFORM4, AW4 or 7

The commands and parameters can be mixed. For example, sending either the string "FUNCTION AW1;" or "FU 4;" will select the Arb 1 function.

3. **Select the Arb Clock Rate.** Send the frequency command followed by its parameter. Sample Period, Block Period, and Block Frequency are not allowed over the GPIB.
Frequency Commands: FREQUENCY or FR.
Sample Frequency Parameters: Value in Hz between 1E-3 and 2E7.
4. **Output Setup.** Set up The amplitude, offset, output, and output impedance are as described in paragraph 3.5.3.2.
5. **Terminate the command string.** Send the Execute command "EX" to terminate the command string. The Model 95 also accepts the FASTEXECUTE command (FE) which executes the command string significantly faster than the EXECUTE command. However, FASTEXECUTE only works when the frequency, amplitude, offset, or dc offset is changed, and the string is executed without any error checking.

Remember, this paragraph only covers how to setup the Model 95's Arb waveforms; paragraph 3.5.18 describes how to create and edit the Arb waveforms.

Example

The following example uses a GPIB command string to setup the Model 95 to produce a 2kHz Arb waveform (Arb 3), 1.5Vpp at the unbalanced output with 50 Ω impedance.

"MODE C; FU AW3; FR 2E3;AM 1.5; OP 1; OS U50;EX"

3.5.7 Triggered Mode

In the triggered mode, the Model 95's output remains quiescent until triggered by a trigger source. A functions can be triggered. When triggered, the Model 95 produces one complete waveform and returns to the quiescent state. The Model 95 can be triggered from an external source such as a signal at the TRIG/FREQ IN connector, the front panel MAN TRIG key, or a GPIB command. In addition, the unit can be triggered using its own internal synthesizer as a trigger source. For proper operation, the trigger source frequency must be less than the output frequency.

3.5.7.1 Internal Trigger

Local Operation

After power on (paragraph 3.5.2), use the following steps to set up the Model 95 for triggered waveform output.

1. **Select the Mode.** Use the MODE key (22) to step to the triggered mode (TRIG indicator lit (23)). To step backwards through the modes, press the SHIFT key and then hold down the MODE key. Release the MODE key when the indicator lights to select the mode.
2. **Select the Internal Trigger.** Use the TRG/LOCK SOURCE key (11) to step to internal source (INTRIG).
3. **Set the Trigger Frequency.** Press the TRIG FREQ key (27) to display the current internal frequency. Use the knob (41) and the keypad (39) to change the trigger frequency. Use the KNOB key (39) to activate the Knob. The knob automatically enters the new trigger frequency. When using the keypad, press the ENTER key to accept the new trigger frequency. Internal trigger frequency range is 1mHz to 20 MHz or 1000s to 0.0005ms. Press SHIFT and the Trigger Frequency's UNITS key (27) to alternate between frequency (TFREQ) and period (TPER). After the SHIFT-UNITS key combination the knob may be used to toggle between the units.

4. **Set up the Function, Frequency, Amplitude, Offset, and Output.** If sine, triangle, or square waveform is selected, set up the Model 95 the same as described in paragraph 3.5.3.1. If variable symmetry waveform is selected, refer to paragraph 3.5.4.1.
5. **Arb Waveforms.** If Arb waveforms are selected, set up the Model 95 the same as described in paragraph 3.5.6.1.

GPIB Operation

After instrument setup (paragraph 3.5.1) and power on (paragraph 3.5.2), use the following steps to set up the Model 95 for triggered output. The examples shown are terminated with a semicolon (;) which indicates the command is part of a string. If only the one command is sent to the Model 95, replace the semicolon with EXECUTE or EX.

1. **Select the Mode.** Send the Mode command followed by the triggered parameter.
 Mode Commands: MODE or MO
 Triggered Parameters: TRIGGER, T, or 1.
 The commands and parameters can be mixed; "MODE TRIGGER;" , "MO 1;" , "MODE T;" , or "MO T;" will select the triggered mode.
2. **Select the Internal Trigger Source.** Send the trigger Source command and Internal parameter to select the internal trigger source.
 Source Command: SOURCE or SRC.
 Internal Source Parameter: INTERNAL, I, or 0.
 For example send "SRC 0;" to select the internal trigger source.
3. **Select the Internal Trigger Frequency.** Send the internal trigger frequency command followed by its parameter.
 Internal Trigger Frequency Command: TRIGGERFREQ or TF.
 Internal Trigger Frequency Parameters: Values in Hz between 1E-3 and 20E6.
 Values can be entered in any format. For example 2kHz can be entered as 2000, 2E3, 20E2, etc.
 For example sending either "TRIGGERFREQ 1E6;" or "TF 1000000;" will select a 1MHz internal trigger frequency.
4. **Set up the Function, Frequency, Amplitude, Offset, and Output.** If sine, triangle, or square waveforms is selected, set up the same as described in paragraph 3.5.3.2. If variable symmetry waveforms are selected, refer to paragraph 3.5.4.2.
5. **Arb Waveforms.** If Arb waveforms are selected, setup the same as describe in paragraph 3.5.6.2

Example

The following example uses a GPIB command string to set up the Model 95 to produce a single 2kHz, 1.5Vpp triangle waveform which is triggered by the internal 100Hz trigger source. The output is the unbalanced 50Ω output .

"MODE T; SRC 0; TF 1E2; FU T; FR 2E3; AM 1.5; OP 1; OS U50;EX"

3.5.7.2 External Trigger

Local Operation

After power on (paragraph 3.5.2), use the following steps to set up the Model 95 for triggered waveform output.

1. **Select the Mode.** Use the MODE key (22) to step to the triggered mode (TRIG indicator lit (23)).

To step backwards through the modes, press the SHIFT key and then hold down the MODE key. Release the MODE key when the indicator lights to select the mode.

2. **Select the External Trigger.** Use the TRG/LOCK SOURCE key (11) to step to EXTERNAL SOURCE.
3. **Connect the External Trigger Source.** Connect the external trigger source to the TRIG/FREQ IN connector (12). To read the frequency of the external source, press the TRIG FREQ key (27). The TRIG FREQ key must be pressed each time the frequency is to be read. The EXT indicator (10) is lit. The Model 95 accepts an external signal from dc to 20 MHz either a logic level or bipolar sine wave. The Model 95 triggers on the positive-going edge at the zero-crossing point.
4. **Set up the Function, Frequency, Amplitude, Offset, and Output.** If sine, triangle, and square waveforms are selected, set up the Model 95 the same as described in paragraph 3.5.3.1. If variable symmetry waveform is selected, refer to paragraph 3.5.4.1.
5. **Arb Waveforms.** If Arb waveforms are selected, set up the Model 95 the same as described in paragraph 3.5.6.1.

Manual Trigger Use the MAN TRIG key (25) to trigger the generator. When the key is pressed, the Model 95 produces one complete cycle of the selected waveform.

GPIB Operation

After instrument setup (paragraph 3.5.1) and power on (paragraph 3.5.2), use the following steps to set up the Model 95 for triggered waveform output. The examples shown are terminated with a semicolon (;) which indicates the command is part of a string. If only the one command is sent to the Model 95, replace the semicolon with EXECUTE or EX.

1. **Select the Mode.** Send the Mode command followed by the trigger parameter.
Mode Commands: MODE or MO
Continuous Parameters: TRIGGER, T, or I.
The commands and parameters can be mixed; "MODE TRIGGER;", "MO 1;", "MODE T;", or "MO T;" will select the triggered mode.
2. **Select the External Trigger Source.** Send the Source command and parameter to select the external trigger source.
Source Command: SOURCE or SRC.
External Trigger Source Parameter: EXTERNAL, E, or 1.
For example, send "SRC 1;" to select the external trigger source.
3. **Connect the External Trigger Source.** Connect the external trigger source to the TRIG/FREQ IN connector (12). The Model 95 accepts an external signal from dc to 20 MHz either a logic level or bipolar sine wave. The Model 95 triggers on the positive-going edge at the zero-crossing point.
4. **Set up the Function, Frequency, Amplitude, Offset, and Output.** If sine, triangle, and square waveforms are selected, set up the same as described in paragraph 3.5.3.2. If variable symmetry waveforms are selected, refer to paragraph 3.5.4.2.
5. **Arb Waveforms.** If Arb waveforms are selected, set up the Model 95 same as described in paragraph 3.5.6.2 .

Example

The following example uses a GPIB command string to set up the Model 95 to produce a single 2kHz, 1.5Vpp triangle waveform which is triggered from an external source. The output is from the unbalanced output with 50Ω impedance.

“MODE T; SRC 1; FU T; FR 2E3; A 1.5; OP 1; OS U50;EX”

Triggering with GPIB Commands. To trigger the Model 95 over the GPIB send the following command:
Trigger Command: TRIGGER or TRG.

3.5.8 Gated Mode

The gated mode is identical to the triggered mode, except the output from the Model 95 supplies continuous waveforms as long as the “trigger” is true. All waveforms can be gated. When gated, the Model 95 starts from the quiescent state, produces continuous waveforms, and returns to the quiescent state. Either the internal (synthesizer) or external trigger source gates the generator. The Model 95 externally gates using a signal at the TRIG/FREQ IN connector, the front panel MAN TRIG key, or a GPIB command. For proper operation, the trigger source frequency must be less than the output

3.5.8.1 Internal Gate

In the internal gate mode, the Model 95 uses its internal trigger source to gate the generator. The gate on to gate off ratio while using the internal source is 1:1 (50%).

Local Operation

After power on (paragraph 3.5.2), use the following steps to set up the Model 95 for gated waveform output.

1. **Select the Mode.** Use the MODE key (22) to step to the gated mode (GATE indicator lit (23)). To step backwards through the modes, press the SHIFT key and then hold down the MODE key. Release the MODE key when the indicator lights to select the mode.
2. **Select the Internal Trigger Source (Gate).** Use the TRG/LOCK SOURCE key (11) to step to internal gate (INTGATE) source.
3. **Set the Gate Frequency.** Use the TRIG FREQ key to display the currently selected internal frequency. Use the knob (41) and the keypad (39) to change the trigger frequency. Use the KNOB key (39) to activate the Knob. The knob automatically enter the new gate frequency. When using the keypad, press the ENTER key to accept the new gate frequency. Internal gate frequency range is 1mHz to 20 MHz or 1000s to 0.0005ms. Press the SHIFT and the Trigger Frequency’s UNITS key (27) to alternate between frequency (TFREQ) and period (TPER). After the SHIFT–UNITS key combination the knob may be used to toggle between the units.
4. **Set up the Function, Frequency, Amplitude, Offset, and Output.** If sine, triangle, and square waveforms are selected, set up the same as described in paragraph 3.5.3.1. If variable symmetry waveforms are selected, refer to paragraph 3.5.4.1.
5. **Arb Waveforms.** If an Arb waveform is selected, set up the Model 95 the same as described in paragraph 3.5.6.1.

GPIB Operation

After instrument setup (paragraph 3.5.1) and power on (paragraph 3.5.2), use the following steps to set up the Model 95 for gated output. The examples shown are terminated with a semicolon (;) which indicates the command is part of a string. If only the one command is sent to the Model 95, replace the semicolon with EXECUTE or EX.

1. **Select the Mode.** Send the Mode command followed by the gate parameter.
Mode Commands: MODE or MO
Gated Parameters: GATE, G, or 2.

The commands and parameters can be mixed; "MODE GATE;" , "MO 2;" , "MODE G;" , or "MO G;" will select the gated mode.

2. **Select the Internal Gate Source** Send the Source command and parameter to select the internal source.
Source Command: SOURCE or SRC.
Internal Source Parameter: INTERNAL, I, or 0.
For example send "SRC 0;" to select the internal source.
3. **Select the Internal Trigger Frequency.** Send the internal trigger frequency command followed by its parameter.
Internal Trigger Frequency Command: TRIGGERFREQ or TF.
Internal Trigger Frequency Parameters: Values in Hz between 2E-3 and 20E6.
Values can be entered in any format. For example 2kHz can be entered as 2000, 2E3, 20E2, etc.
For example sending either "TRIGGERFREQ 1E6;" or "TF 1000000;" will select a 1MHz internal trigger frequency.
4. **Set up the Function, Frequency, Amplitude, Offset, and Output.** If sine, triangle, or square waveforms is selected, set up the Model 95 the same as described in paragraph 3.5.3.2. If variable symmetry waveforms are selected, refer to paragraph 3.5.4.2.
5. **Arb Waveform.** If Arb waveforms are selected, set up the Model 95 the same as described in paragraph 3.5.6.2.

Example

The following example uses a GPIB command string to setup the Model 95 to produce a single 2kHz, 1.5Vpp triangle waveform which is triggered by the internal trigger source at a 100Hz rate. The output is from the unbalanced output with 50Ω impedance.

"MODE G; SRC 0; TF 1E2; FU T; FR 2E3; AM 1.5; OP 1; OS U50;EX"

3.5.8.2 External Gate

In the externally (triggered) gated mode, either an external triggering signal, a manual trigger, or a GPIB command gates the generator. The gate on to gate off time depends on the period when the trigger input signal is greater than the Model 95's trigger threshold.

Local Operation

After power on (paragraph 3.5.2), use the following steps to set up the Model 95 for gated waveform output.

1. **Select the Mode.** Use the MODE key (22) to step to the gated mode (GATE indicator lit (23)). To step backwards through the modes, press the SHIFT key and then hold down the MODE key. Release the MODE key when the indicator lights to select the mode.
2. **Select the External Gate (Trigger) Source.** Use the TRG/LOCK SOURCE key (11) to step to external source (EXTGATE).
3. **Connect the External Gate (Trigger) Source.** Connect the external gate source to the TRIG/FREQ IN connector (12). To read the frequency of the external source, press the TRIG FREQ key (27). The TRIG FREQ key must be pressed each time the frequency is to be read. The EXT indicator (10) is lit. The Model 95 accepts an external signal from dc to 20 MHz either a logic level or bipolar sine wave. The Model 95 triggers on the positive-going edge at the zero-crossing point.
4. **Set up the Function, Frequency, Amplitude, Offset, and Output.** If sine, triangle, or square waveform is selected, set up the Model 95 the same as described in paragraph 3.5.3.1. If variable symmetry waveforms are selected, refer to paragraph 3.5.4.1.

5. **Arb Waveform.** If Arb waveforms are selected, set up the Model 95 the same as described in paragraph 3.5.6.1.

Manual Trigger Use the MAN TRIG key (25) to gate the generator. When the key is pressed in the Model 95 produces a continuous output until the key is released.

GPIB Operation

After instrument setup (paragraph 3.5.1) and power on (paragraph 3.5.2), use the following steps to set up the Model 95 for triggered waveform output. The examples shown are terminated with a semicolon (;) which indicates the command is part of a string. If only the one command is sent to the Model 95, replace the semicolon with EXECUTE or EX.

1. **Select the Mode.** Send the Mode command followed by the gate parameter.
Mode Commands: MODE or MO
Continuous Parameters: GATE, G, or 2.
The commands and parameters can be mixed; "MODE GATE;", "MO 2;", "MODE G;", or "MO G;" will select the triggered mode.
2. **Select the External Source.** Send the Source command and parameter to select the gate (trigger) source.
Source Command: SOURCE or SRC.
External Source Parameter: EXTERNAL, E, or 1.
For example, send "SRC 1;" to select the external trigger source.
3. **Connect the External Trigger Source.** Connect the external trigger source to the TRIG/FREQ IN connector (12). The Model 95 accepts an external signal from dc to 20 MHz either a logic level or bipolar sine wave. The Model 95 triggers on the positive-going edge at the zero-crossing point.
4. **Set up the Function, Frequency, Amplitude, Offset, and Output.** If sine, triangle, or square waveform is selected, set up the Model 95 the same as described in paragraph 3.5.3.2. If variable symmetry waveforms are selected, refer to paragraph 3.5.4.2.
5. **Arb Waveforms.** If Arb waveforms are selected, set up the Model 95 the same as described in paragraph 3.5.6.2.

Example

The following example uses a GPIB command string to set up the Model 95 to produce a gated 2kHz, 1.5Vpp triangle waveforms which are triggered by an external source. The output is from the unbalanced output with 50Ω impedance.

"MODE G; SRC 1; FU T; FR 2E3; AM 1.5; OP 1; OS U50;EX"

Gating with GPIB Commands

The Model 95 generates waveforms starting with the gate on command and ending with the gate off command. To Gate the Model 95 over the GPIB send the following commands:

Gate On Command: GATEON or GN.

Gate Off Command: GATEOFF or GF.

3.5.9 Burst Mode

The burst mode is identical to the gated mode except the Model 95 produces an user-defined number of cycles when triggered. In the burst mode, the Model 95 generates from 1 to 1,000,000 cycles. The Model 95 allows either the internal (synthesizer) or external trigger source to start the burst. External trigger sources can be the TRIG/FREQ IN connector, the MAN TRIG key, or a GPIB command.

3.5.9.1 Internally Triggered Bursts

In the internally triggered burst mode, the Model 95 uses its internal synthesizer to trigger the generator.

Local Operation

After power on (paragraph 3.5.2), use the following steps to set up the Model 95 for triggered waveform output.

1. **Select the Mode.** Use the MODE key (22) to step to the burst mode (BURST indicator lit (23)). To step backwards through the modes, press the SHIFT key and then hold down the MODE key. Release the MODE key when the indicator lights to select the mode.
2. **Select the Internal Trigger.** Use the TRG/LOCK SOURCE key (11) to step to internal source (INTTRIG).
3. **Set the Trigger Frequency.** Use the TRIG FREQ key to display the currently selected internal frequency. Use the knob (41) or the keypad (39) to change the trigger frequency. The knob automatically enter the new trigger frequency. When using the keypad, press the ENTER key to accept the new trigger frequency. Internal trigger frequency range is 1mHz to 20 MHz or 1000s to 0.0005ms. Press SHIFT and the Trigger Frequency's UNITS key (27) to alternate between frequency (TFRQ) and period (TPER). After the SHIFT-UNITS key combination the knob may be used to toggle between the units.
4. **Enter the Burst Count.** Press the BURST CNT key (24) to display the currently selected burst count. Use the knob (41) and keypad(39) to change the burst count. The knob automatically enters the new value. When using the keypad press the ENTER key to accept the new value. Burst count values range from 1 to 1,000,000 cycles.
5. **Set up the Function, Frequency, Amplitude, Offset, and Output.** If sine, triangle, or square waveform is selected, set up the Model 95 the same as described in paragraph 3.5.3.1. If variable symmetry waveforms are selected, refer to paragraph 3.5.4.1.
6. **Arb Waveforms.** If Arb waveforms are selected, set up the Model 95 the same as described in paragraph 3.5.6.1.

GPIB Operation

After instrument setup (paragraph 3.5.1) and power on (paragraph 3.5.2), use the following steps to setup the Model 95 for a waveform burst output. The examples shown are terminated with a semicolon (;) which indicates the command is part of a string. If only the one command is sent to the Model 95, replace the semicolon with EXECUTE or EX.

1. **Select the Mode.** Send the Mode command followed by the burst parameter.
Mode Commands: MODE or MO
Burst Parameters: BURST, B, or 3.
The commands and parameters can be mixed; "MODE BURST;", "MO 3;", "MODE B;", or "MO B;" will select the burst mode.
2. **Select the Internal Trigger Source.** Send the trigger source command and it parameter to select the internal trigger source.
Source Command: SOURCE or SRC.
Internal Source Parameter: INTERNAL, I, or 0.
For example send "SRC 0;" to select the internal source.

3. **Select the Internal Trigger Frequency.** Send the internal trigger frequency command followed by its parameter.
 Internal Trigger Frequency Command: TRIGGERFREQ or TF.
 Internal Trigger Frequency Parameters: Values in Hz between 2E-3 and 20E6.
 Values can be entered in any format. For example 2kHz can be entered as 2000, 2E3, 20E2, etc.
 For example sending either "TRIGGERFREQ 1E6;" or "TF 1000000;" will select a 1MHz internal trigger frequency.
4. **Enter the Burst Count.** Send the burst count command and its parameter to enter the burst count.
 Burst Count Command: BURSTCOUNT or B.
 Burst count Parameter: 1 to 1E6.
5. **Set up the Function, Frequency, Amplitude, Offset, and Output.** If sine, triangle, or square waveform is selected, set up the Model 95 the same as described in paragraph 3.5.3.2. If variable symmetry waveforms are selected, refer to paragraph 3.5.4.2.
6. **Arb Waveforms.** If Arb waveforms are selected, set up the Model 95 the same as described in paragraph 3.5.6.2.

Example

The following example uses a GPIB command string to set up the Model 95 to produce a burst of ten 2kHz, 1.5Vpp triangle waveforms which are triggered by the Model 95's internal synthesizer at a 1Hz rate. The output is from the unbalanced output with 50Ω impedance.

"MODE B; B 10; SRC 0; TF 1E0; FU T; FR 2E3; AM 1.5; OP 1; OS U50;EX"

3.5.9.2 External Triggered Bursts

In the external triggered burst mode, either an external triggering signal, a manual trigger, or a GPIB command gates the generator.

Local Operation

After power on (paragraph 3.5.2), use the following steps to set up the Model 95 for triggered waveform output.

1. **Select the Mode.** Use the MODE key (22) to step to the burst mode (BURST indicator lit (23)). To step backwards through the modes, press the SHIFT key and then hold down the MODE key. Release the MODE key when the indicator lights to select the mode.
2. **Select the External Trigger.** Use the TRG/LOCK SOURCE key (11) to step to external source EXTTRIG).
3. **Connect the External Trigger Source.** Connect the external triggering source to the TRIG/FREQ IN connector (12). To read the frequency of the external source, press the TRIG FREQ key (27). The TRIG FREQ key must be pressed each time the frequency is to be read. The EXT indicator (10) is lit. The Model 95 accepts an external signal from dc to 20MHz either a logic level or bipolar sine wave. The Model 95 triggers on the positive-going edge at the zero-crossing point.
4. **Enter the Burst Count.** Press BURST CNT key (24) to display the current burst count. Use the knob (41) or keypad to change the burst count. The knob automatically enters the new value. When using the keypad, press the ENTER key to accept the new value (1 to 1000000)
5. **Setup the Function, Frequency, Amplitude, Offset, and Output.** If sine, triangle, or square waveform is selected, set up the Model 95 the same as described in paragraph 3.5.3.1. If variable symmetry waveforms are selected, refer to paragraph 3.5.4.1.

6. **Arb Waveforms.** If Arb waveforms are selected, set up the Model 95 the same as described in paragraph 3.5.6.1.

Manual Trigger Use the MAN TRIG key (25) to trigger the burst. When the key is pressed in the Model 95 begins the burst count.

GPIB Operation

After instrument setup (paragraph 3.5.1) and power on (paragraph 3.5.2), use the following steps to set up the Model 95 for burst output. The examples shown are terminated with a semicolon (;) which indicates the command is part of a string. If only the one command is sent to the Model 95, replace the semicolon with EXECUTE or EX.

1. **Select the Mode.** Send the Mode command followed by the burst parameter.
Mode Commands: MODE or MO
Burst Parameters: BURST, B, or 3.
The commands and parameters can be mixed; "MODE BURST;", "MO 3;", "MODE B;", or "MO B;" will select the burst mode.
2. **Select the External Trigger Source.** Send the Source command and parameter to select the external source.
Source Command: SOURCE or SRC.
External Source Parameter: EXTERNAL, E, or 1.
For example, send "SRC 1;" to select the external trigger source.
3. **Connect the External Trigger Source.** Connect the external trigger source to the TRIG/FREQ IN connector (12). The Model 95 accepts an external signal from dc to 20 MHz either a logic level or bipolar sine wave. The Model 95 triggers on the positive-going edge at the zero-crossing point.
4. **Enter the Burst Count.** Send the burst count command followed by the burst parameter.
Burst Count Command: BURSTCOUNT or B.
Burst count Parameter: 1 to 1E6.
5. **Set up the Function, Frequency, Amplitude, Offset, and Output.** If sine, triangle, or square waveform is selected, set up the Model 95 the same as described in paragraph 3.5.3.2. If variable symmetry waveforms are selected, refer to paragraph 3.5.4.2.
6. **Arb Waveforms.** If Arb waveforms are selected, set up the Model 95 the same as described in paragraph 3.5.6.2.

Example

The following example uses a GPIB command string to setup the Model 95 to produce a burst of ten 2kHz, 1.5Vpp triangle waveforms which are triggered by an external trigger source. The output is from the unbalanced output with 50Ω impedance.

"MODE B; B 10; SRC 1; FU T; FR 2E3; A M 1.5; OP 1; OS U50;EX"

Triggering with GPIB Commands. To trigger the Model 95 over the GPIB send the following command:
Trigger Command: TRIGGER or TRG.

3.5.10 Amplitude Modulation

In Amplitude Modulation (AM), a modulating signal controls the magnitude of the Model 95's output. The Model 95 (AM selected) produces the carrier (frequency, function, and amplitude). All waveforms, including Arb waveforms, can be amplitude modulated. When the AM mode is selected (Local Operation), the unit shows a scale factor ($x \cdot xV = FS$) which represents the peak to peak voltage required to produce full scale (100%) modulation. The scale factor displayed depends on the Amplitude value. For example, for an amplitude of 7.5Vpp, the AM scale factor will be $4V = F.S. (100\%)$. Also the input value varies linearly

which means for a $4V = \text{F.S.}$ scale factor a $2V_{pp}$ input signal produces 50% modulation. Exceeding 100% modulation can cause distorted outputs. In the AM, the continuous Amplitude is limited to $7.5V_{pp}$ or less. Figure 3-12 illustrates the Model 95 AM setup.

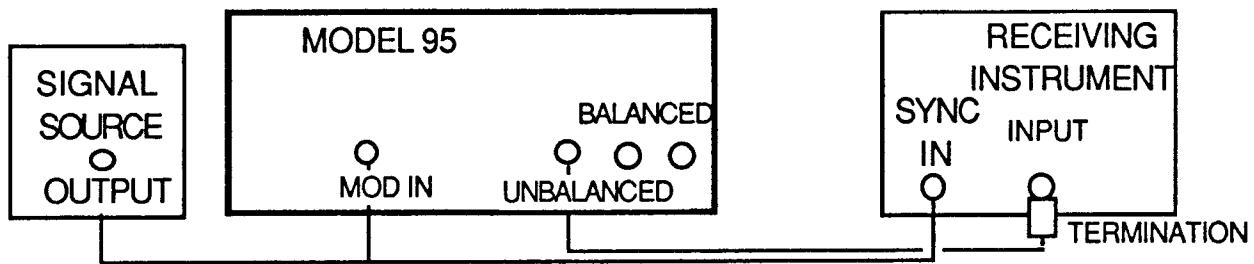

Figure 3-12. Model 95 AM and FM/VCG Setup

3.5.10.1 Local Operation

After power on (paragraph 3.5.2), use the following steps to setup the Model 95 for amplitude modulation.

1. **Select the Mode.** Press the MODE key (22) to step to the AM mode (AM indicator lit (23)). To step backwards through the modes, press the SHIFT key and then hold down the MODE key. Release the MODE key when the indicator lights to select the mode. If the Amplitude is greater than $7.5V$, the AM mode cannot be selected.
2. **Set up the Function, Frequency, Amplitude, Offset, and Output.** If sine, triangle, or square waveform is selected, set up the the Model 95 the same as described in paragraph 3.5.3.1. If variable symmetry waveforms are selected, refer to paragraph 3.5.4.1. The dc function is not allowed in the AM mode.
3. **Arb Waveform.** If Arb waveforms are selected, set up the Model 95 the same as described in paragraph 3.5.6.1.
4. **Connect the Modulating Signal.** Connect the modulating signal to the MOD IN connector (30). Frequency range of the modulating signal is dc to 150 kHz, and amplitude range is 0 to $4V_{pp}$. The modulation depth is directly proportional to the modulation signal's amplitude. The AM scale factor is shown on the display when MODE: AM is selected. When the Amplitude is changed, MODE: AM must be selected again to view the new scale factor.

3.5.10.2 GPIB Operation

1. **Select the Mode.** Send the Mode command followed by the AM parameter.
 Mode Commands: MODE or MO
 AM Parameter: A or 4.
 The commands and parameters can be mixed; "MODE AM;", "MO 4;", "MODE A;", or "MO A;" will select the AM mode.
2. **Set up the Function, Frequency, Amplitude, Offset, and Output.** If sine, triangle, or square waveform is selected, set up the Model 95 the same as described in paragraph 3.5.3.2. If variable symmetry waveform is selected, refer to paragraph 3.5.4.2. To select the AM mode, the amplitude must be less than $7.5V_{pp}$.
3. **Arb Waveforms.** If Arb waveforms are selected, set up the Model 95 the same as described in paragraph 3.5.6.2.
4. **Connect the Modulating Signal.** Connect the modulating signal to the MOD IN connector (30). Frequency range of the modulating signal is dc to 150 kHz, and amplitude range is 0 to $4V_{pp}$. The

amount of modulation depends on the "scale factor". There is no way to view the scale factor via the GPIB. For more information on scale factor, see the AM paragraph introduction and paragraph 3.5.10.1.

Example

The following example uses a GPIB command string to setup the Model 95 for the AM mode. In this example it is assumed a 10 kHz sine wave of 4Vpp is connected to the MOD IN connector. The Model 95 is set up for 1MHz sine wave and the peak to peak amplitude at 100% modulation. The output is from the unbalanced output with 50Ω impedance.

"MODE A; FU SI; FR 1E6; AM 7.5; OP 1; OS U50;EX"

3.5.11 Suppressed Carrier Modulation

In the Suppressed Carrier Modulation mode (SCM), the Model 95 operates much the same as the AM mode, except unmodulated output level will be zero volts. In Suppressed Carrier Modulation (SCM), a modulating signal controls the magnitude of the Model 95's output. The Model 95 (SCM selected) produces the carrier (frequency, function, and amplitude). All waveforms, including Arb waveforms, can be modulated. When the SCM mode is selected (Local Operation), the unit shows a scale factor (2V/V) which represents Volts Output/Volts Input for required to produce an output. For example, the 2V/V scale factor means a 1V input will produce a 2V output. Figure 3-12 illustrates the Model 95 SCM setup.

3.5.11.1 Local Operation

After power on (paragraph 3.5.2), use the following steps to set up the Model 95 for suppressed carrier modulation.

1. **Set up the Function, Frequency Offset, and Output.** If sine, triangle, or square waveform is selected, set up the same as described in paragraph 3.5.3.1. If variable symmetry waveforms are selected, refer to paragraph 3.5.4.1. The dc function is not allowed in the SCM mode.
2. **Select the SCM Mode.** Use the MODE key (22) to step to the SCM mode (SCM indicator lit (23)). The display shows the SCM Scale Factor. To step backwards through the modes, press the SHIFT key and then hold down the MODE key. Release the MODE key when the indicator lights to select the mode.
3. **Select the SCM Scale Factor.** When the SCM is selected, the Model 95 displays a scale factor. There are three scale factors: 2V/V, 0.2V/V, and 0.02V/V (Output Vpp/Input Vpp). Change the scale factors by using the knob. Use the KNOB key (39) to activate the Knob.
4. **Null the Carrier.** During AutoCal the Model 95 calculates the carrier null values, these values will be used in the SCM mode unless the operator needs to improve the carrier null.

To improve carrier null, connect a scope or spectrum analyzer to the Model 95. Press the AMPLITUDE key (5) and the display shows "SCM NULL 00". Rotate the knob or press keys to change the carrier null. Null can be varied between ±500 digits.

5. **Connect the Modulating Signal.** Connect the modulating signal to the MOD IN connector (30). Frequency range of the modulating signal is dc to 1MHz and amplitude range is 0 to 4Vpp. The magnitude of the output is directly proportional to the modulating signal's amplitude.

3.5.11.2 GPIB Operation

1. **Set up the Function, Frequency,, Offset, and Output.** If sine, triangle, or square waveform is selected, set up the Model 95 the same as described in paragraph 3.5.3.2. If variable symmetry waveform is selected, refer to paragraph 3.5.4.2.
2. **Select the SCM Mode** Send the Mode command followed by the SCM parameter.
Mode Commands: MODE or MO
SCM Parameter: SC or 5.

The commands and parameters can be mixed; "MODE SC;", "MO 5;", "MODE SC;", or "MO SC;" will select the suppressed carrier mode.

3. **Connect the Modulating Signal.** Connect the modulating signal to the MOD IN connector (26). Frequency range of the modulating signal is dc to 100 kHz, and amplitude range is 0 to 4Vpp. The modulation depth is directly proportional to the modulation signal's amplitude. The SCM scale factor is fixed at 2V/V when using GPIB commands.

Example

The following example uses a GPIB command string to setup the Model 95 for the SCM mode. In this example it is assumed a 10 kHz sine wave of 4Vpp is connected to the MOD IN connector. The Model 95 is set up for 1MHz sine wave and the peak to peak amplitude at full modulation will be 1.5Vpp. The output is from the unbalanced output with 50Ω impedance.

"MODE 5; FU SI; FR 1E6; AM 1.5; OP 1; OS U50;EX"

3.5.12 Frequency Modulation

In the FM mode, an external signal varies the frequency of the Model 95 about its programmed frequency. The magnitude of the modulating signal determines the maximum frequency deviation, and the frequency of the modulating signal determines the rate of deviation. Figure 3-13 illustrates Model 95 FM setup.

The following steps describe the general FM mode setup.

1. Set the Model 95 to the Continuous mode.
2. Calculate upper and lower modulation frequency limits:
Upper Limit = Center Frequency + Peak Deviation
Lower Limits = Center Frequency – Peak Deviation
Where:
Upper Limit is the upper modulation limit required.
Lower Limit is the lower modulation limit required.
Center Frequency is the desired center frequency (set using the FREQ/SAMP key (4)).
Peak Deviation is desired positive or negative deviation.

Example:

Desired Center Frequency = 200 kHz.

Peak Deviation = ± 25 kHz.

Upper Limit = 200 kHz + 25 kHz
= 225 kHz

Lower Limit = 200 kHz - 25 kHz
= 175 kHz

3. Using table 3-12, find and record the range number that contains the calculated upper limit. Also, verify that range contains the calculated lower limit.

Example:

Range number 8 contains the calculated upper limit of 225 kHz, and the range also contains the calculated lower limit.

Exceeding the Lower Limit will cause output signal distortion.

Table 3-12. Range and Modulation Limits

Range Number	Modulation Upper Limit Range	Modulation Lower Limit	Deviation per Volt
9	2.01 to 20 MHz	20 kHz	2MHz
8	201 kHz to 2.0 MHz	2.0 kHz	200 kHz
7	20.1 to 200 kHz	200 Hz	20 kHz
6	2.01 to 20 kHz	20 Hz	2kHz
5	201 Hz to 2kHz	2Hz	200Hz
4	20.1 to 200Hz	200 mHz	20Hz
3	2.01 to 20Hz	20 mHz	2Hz
2	201 mHz to 2Hz	2mHz	200 mHz
1	20.1 to 200 mHz	2mHz	20 mHz
0	2 to 20 mHz	2mHz	2mHz

4. Calculate the modulation source amplitude (Vpp):

Modulation Amplitude = P-P Deviation + Deviation per Volt

Where:

Modulation Amplitude is the amplitude (Vpp) of the modulating source.

P-P Deviation is the total positive and negative deviation.

Deviation per Volt (see table 3-12) is the Hz/V of the range selected in step 3.

Example:

P-P Deviation = 50 kHz (+ and - 25kHz)

Deviation per Volt from table 3-12 for range 8 = 200 kHz per Volt.

Modulation Amplitude = 50 kHz + 200 kHz/V
= 0.25 Vpp.

5. Set the Model 95 to the upper limit frequency (step 2).
6. Set the Model 95 to the FM mode.
7. Set the Model 95 to the center frequency.
8. Connect the Modulating signal.

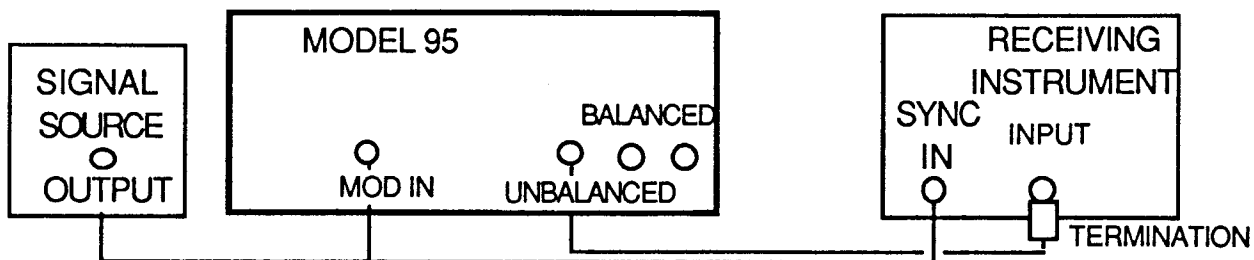

Figure 3-13. Model 95 FM Setup

3.5.12.1 Local Operation

After power on (paragraph 3.5.2), use the following steps to set up the Model 95 for frequency modulation.

1. **Select the Mode.** Use the MODE key (22) to step to the CONT mode (CONT indicator lit (23)). To step backwards through the modes, press the SHIFT key and then hold down the MODE key. Release the MODE key when the indicator lights to select the mode.
2. **Calculate the limits.** Use step 2 in paragraph 3.5.12. to calculate the upper and lower frequency limits.
3. **Select the Upper frequency limit.** Press the FREQ/SAMP key (4) to display the current frequency. Use the keypad (39) or knob (41), if enabled (ENABLE indicator (40) lit), to set up the upper limit frequency; see paragraph 3.5.3.1, item 3. Use the KNOB key (39) to activate the Knob. The knob increments or decrements the value and automatically enters the new value. When using the keypad, enter values as actual number (120) or exponential notation (12E1), press the ENTER key to accept the new value.
4. **Change the Mode.** Use the MODE key (22) to step to the FM mode (FM indicator lit (23)). This "locks" the Model 95 to the fixed frequency range.
5. **Select the Center frequency.** Press the FREQ/SAMP key (4) again, and use the knob or keypad to set up the center frequency; see paragraph 3.5.3.1.
6. **Set up the Function, Amplitude, Offset, and Output.** If sine, triangle, or square waveform is selected, set up the the Model 95 the same as described in paragraph 3.5.3.1. If variable symmetry waveforms are selected, also refer to paragraph 3.5.4.1. The dc function is not allowed in the FM mode.
7. **Arb Waveforms.** If Arb waveforms are selected, set up the Model 95 the same as described in paragraph 3.5.6.1. Only the sample frequency will be modulated.
8. **Calculate the Amplitude of the Modulating Signal.** Use step 4 to calculate the peak to peak voltage required to modulate the Model 95.
9. **Connect the Modulating Signal.** Set the modulating source to the level calculated in item 8, and connect the signal to the MOD IN connector (30). Frequency range of the modulating signal is dc to 100 kHz, and the maximum level is 10Vpp.

3.5.12.2 GPIB Operation

After power on (paragraph 3.5.2), use the following steps to setup the Model 95 for continuous output.

1. **Calculate the limits.** Use step 2 in paragraph 3.5.12. to calculate the upper and lower frequency limits.

2. **Select the Upper frequency limit.** Send the Frequency command followed by the parameter.
 Frequency Commands: FREQUENCY or FR.
 Parameters: Values in Hz between 2E-3 and 20E6. Values can be entered in any format.
 For example 2kHz can be entered as 2000, 2E3, 20E2, etc.
 For example, sending either "FREQUENCY 1E6;" or "FR 1000000;" will select 1MHz.
3. **Select the Mode.** Send the Mode command followed by the FM parameter.
 Mode Commands: MODE or MO
 FM Parameter: F or 6.
4. **Lock the Frequency Range.** Send the Range Lock command followed by its parameter.
 Range Lock Command: RANGELOCK or RA.
 Range Lock Parameter: ON or 1.
 NOTE: Range Lock should be turned off when finished with the FM mode: RA 0.
5. **Select the Center frequency.** Send the Frequency command followed by the parameter.
 Frequency Commands: FREQUENCY or FR.
 Parameters: Values in Hz between 2E-3 and 20E6.
6. **Set up the Function, Amplitude, Offset, and Output.** If sine, triangle, or square waveform is selected, set up the Model 95 the same as described in paragraph 3.5.3.2. If variable symmetry waveforms are selected, also refer to paragraph 3.5.4.2. The dc function is not allowed in the FM mode.
7. **Arb Waveform.** If Arb waveforms are selected, set up the Model 95 the same as described in paragraph 3.5.6.. Only the sample frequency will be modulated.
7. **Calculate the Amplitude of the Modulating Signal.** Use step 4 to calculate the peak to peak voltage required to modulate the Model 95.
8. **Connect the Modulating Signal.** Set the modulating source to the level calculated in item 7, and then connect the modulating signal to the MOD IN connector (30). Frequency range of the modulating signal is dc to 100 kHz and the maximum level is 10Vpp.

Example

The following example uses a GPIB command string to setup the Model 95 for the FM mode. In this example, the output will be a 1.5Vpp sine wave from the 50Ω unbalanced output. To modulate the generator connect a 0.25Vpp signal to the MOD IN/OUT connector.

"MODE F; FR 2E5; RA 1;FU SI; AM 1.5; OP 1; OS U50;EX"

3.5.13 Voltage Controlled Generator – VCG

VCG operation is identical to the FM mode except the Model 95's set frequency becomes the start frequency. In this mode, the voltage applied to the MOD IN connector controls the frequency of the generator. Usually the modulating signal is a dc voltage between 0 and ±10V. Maximum generator frequency change is 1000:1.

The following seven step generally describe the steps to setup the VCG operation.

1. Set the Model 95 to the Continuous mode.
2. Calculate upper and lower modulation frequency limits:
 Upper Limit = Initial Frequency + Frequency Change
 Lower Limits = Initial Frequency – Frequency Change

Where:

Upper Limit is the upper modulation limit required.

Lower Limit is the lower modulation limit required.

Initial Frequency is the starting frequency (set using the FREQ/SAMP key (4)).

Frequency Change is desired positive or negative frequency change.

Example:

Desired Center Frequency = 200 kHz.

Frequency Change = (+25kHz) and (- 10 kHz)

Upper Limit = 200 kHz + 25kHz

= 225 kHz

Lower Limit = 200 kHz - 10 kHz

= 190 kHz

- Using table 3-12, find the range number that contains the calculated upper limit. Also, verify that range contains the calculated lower limit.

Example:

Range number 8 contains the calculated upper limit of 225 kHz, and the range also contains the calculated lower limit 190 kHz.

Exceeding the Lower Limit will cause output signal distortion.

- Calculate the level of the external dc source:

VCG Voltage = Frequency Change + Deviation per Volt

Where:

VCG Voltage is the external dc source voltage ($\pm V_{dc}$).

Frequency Change is the positive or negative frequency change.

Deviation per Volt (see table 3-FM) is the Hz/V of the range selected in step 3.

Example:

Frequency Change = +25 kHz and -10 kHz

Deviation per Volt from table 3-FM for range 8 = 200 kHz per Volt.

VCG Voltage = +25 kHz + 200 kHz/V

= +0.125Vdc

VCG Voltage = -10 kHz + 200 kHz/V

= -0.05Vdc

- Set the Model 95 to the upper limit frequency (step 2).

- Set the Model 95 to the FM mode.

- Set the Model 95 to the initial frequency

- Connect the Modulating signal.

3.5.13.1 Local Operation

After power on (paragraph 3.5.2), use the following steps to setup the Model 95 for VCG operation.

- Select the Mode.** Use the MODE key (22) to step to the CONT mode (CONT indicator lit (23)). To step backwards through the modes, press the SHIFT key and then hold down the MODE key. Release the MODE key when the indicator lights to select the mode.
- Calculate the limits.** Use step 2 in paragraph 3.5.13. to calculate the upper and lower frequency limits.

3. **Select the Upper frequency limit.** Press the **FREQ/SAMP** key (4) to display the current frequency. Use the keypad (39) or knob (41), if enabled (**ENABLE** indicator (40) lit), to set up the upper limit frequency; see paragraph 3.5.3.1, item 3. Use the **KNOB** key (39) to activate the Knob. The knob increments or decrements the value and automatically enters the new value. When using the keypad, enter values as actual number (120) or exponential notation (12E1), press the **ENTER** key to accept the new value.
4. **Change the Mode.** Use the **MODE** key (22) to step to the **FM** mode (**FM** indicator lit (23)). This "locks" the Model 95 to the fixed frequency range.
5. **Select the Initial frequency.** Press the **FREQ/SAMP** key (4) again, and use the knob or keypad to set up the initial frequency; see paragraph 3.5.3.1.
6. **Set up the Function, Amplitude, Offset, and Output.** If sine, triangle, and square waveforms are selected, set up the same as described in paragraph 3.5.3.1. If variable symmetry waveforms are selected, also refer to paragraph 3.5.4.1. The dc function is not allowed for VCG operation.
7. **Calculate the VCG Voltage.** Use step 4 to calculate the voltages required to change the generator's voltage.
8. **Connect the VCG Voltage.** Set the voltage source to the level calculated in item 4, and then connect the voltage to the **MOD IN** connector (30).

3.5.13.2 GPIB Operation

After power on (paragraph 3.5.2), use the following steps to set up the Model 95 for VCG operation.

1. **Calculate the Limits.** Use step in paragraph 3.5.13 to calculate the upper and lower frequency limits.
2. **Select the Upper Frequency Limit.** Send the **Frequency** command followed by the parameter.
 Frequency Commands: **FREQUENCY** or **FR**.
 Parameters: Values in Hz between 2E-3 and 20E6.
 Values can be entered in any format. For example 2kHz can be entered as 2000, 2E3, 20E2, etc.
 For example, sending either "FREQUENCY 1E6;" or "FR 1000000;" will select 1MHz.
3. **Lock the Frequency Range.** Send the **Range Lock** command followed by its parameter.
 Range Lock Command: **RANGELOCK** or **RA**.
 Range Lock Parameter: **ON** or **1**.
NOTE: Range Lock should be turned off when finished with the **FM** mode: **RA 0**.
4. **Change the Mode.** Send the **Mode** command followed by the **FM** parameter.
 Mode Commands: **MODE** or **MO**
 FM Parameter: **F** or **6**.
5. **Select the initial frequency.** Send the **Frequency** command followed by the parameter.
 Frequency Commands: **FREQUENCY** or **FR**.
 Parameters: Values in Hz between 2E-3 and 20E6.
6. **Set up the Function, Amplitude, Offset, and Output.** If sine, triangle, or square waveforms are selected, set up the same as described in paragraph 3.5.3.2. If variable symmetry waveform is selected, refer to paragraph 3.5.4.2. The dc function is not allowed in the VCG mode.
7. **Arb Waveform.** If Arb waveforms are selected, set up the Model 95 the same as described in paragraph 3.5.6.2. Only the sample frequency will be modulated.

8. Calculate the VCG Voltage. Use step 4 to calculate the peak to peak voltage required to modulate the Model 95.
9. Connect the VCG Voltage. Set the voltage source to the level calculated in item 4, and then connect the voltage to the MOD IN connector (30). The maximum level is $\pm 10\text{Vdc}$.

Example

The following example uses a GPIB command string to set up the Model 95 for the VCG operation. In this example the output will be a 1.5Vpp sine wave from the 50 Ω unbalanced output. To change the frequency apply +0.125Vdc to the MOD IN/OUT connector to change the frequency to 225 kHz. Apply -0.05Vdc to change the frequency to 190 kHz..

"MODE F; FR 2E5; RA 1;FU SI; AM 1.5; OP 1; OS U50;EX"

3.5.14 Continuous Sweep

In continuous mode, the Model 95 continuously sweeps between a start and stop frequency either linearly or logarithmically. The sweep time can be varied between 0.1 and 100 seconds. The sweep start and sweep stop frequencies can be between 1MHz and 20 MHz. If the start frequency is less than the stop frequency, the generator sweeps up in frequency. If the start frequency is greater than the stop frequency, the generator sweep down in frequency. Maximum sweep range is three decades (1000: 1 frequency change). If the frequency range exceeds three decades, the first frequency set will be pulled to within three decades. Figure 3-14 shows the instrument setup for sweep.

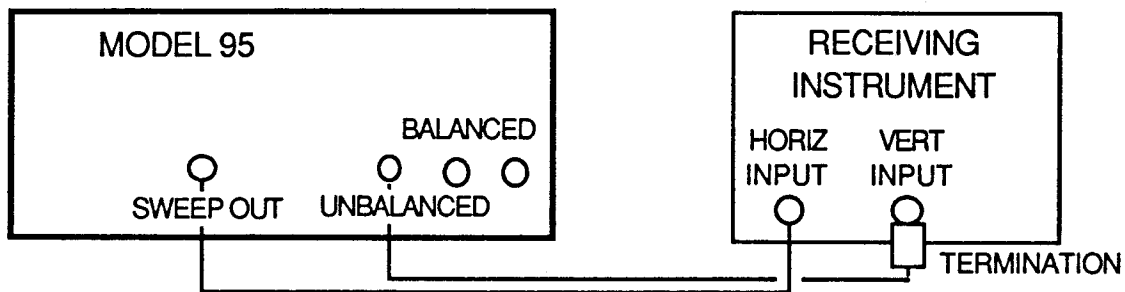

Figure 3-14. Model 95 Continuous Sweep Setup

3.5.14.1 Local Operation

After power on (paragraph 3.5.2), use the following steps to setup the Model 95 for continuous sweep.

1. Select the Sweep Mode. Use the MODE key (22) to step to the sweep mode (SWEEP indicator (23) lit). To step backwards through the modes, press the SHIFT key and then hold down the MODE key. Release the MODE key when the indicator lights to select the mode.
2. Select the Start Frequency. Use the SWEEP MODE (26) key to step to the start frequency. When START is displayed, the current start frequency is shown. To change the start frequency, use the keypad (39) or the knob (41), if enabled (ENABLE indicator (40) lit). Use the KNOB key (39) to activate the Knob. The knob increments or decrements the value starting from the flashing digit (Knob key (39)) and automatically enters the new value. When using the keypad, enter values as actual number (5000) or exponential notation (5E3), press the ENTER key to accept the new value.
3. Select the Stop Frequency. Use the SWEEP MODE (26) key to step to stop frequency. When STOP is displayed, the current stop frequency is shown. To change the start frequency, use the keypad (39) or the knob (41), if enabled (ENABLE indicator (40) lit). Use the KNOB key (39) to activate the Knob. The knob increments or decrements the value starting from the flashing digit (Knob key (39)) and

automatically enters the new value. When using the keypad, enter values as actual number (5000) or exponential notation (5E3), press the ENTER key to accept the new value.

4. **Select the Sweep Rate.** Use the TIME key (28) to select the sweep rate. Sweep rate is the time it takes the Model 95 to sweep between the start and stop frequencies. To change the sweep time, use the keypad (39) or the knob (41), if enabled (ENABLE indicator (40) lit). Use the KNOB key (39) to activate the Knob. The knob increments or decrements the value starting from the flashing digit (Knob key (39)) and automatically enters the new value. When using the keypad, enter values as actual number (90) or exponential notation (9E1), press the ENTER key to accept the new value. Sweep time values are between 100ms and 100s. Press SHIFT and Time's UNITS key to shift between frequency and period. After the SHIFT-UNITS key combination the knob may be used to toggle between the units.
5. **Select Linear or Logarithmic Sweep.** Press the SHIFT key (31) and then the LIN/LOG key (28) to select the sweep function. Each time the SHIFT LIN/LOG key combination is pressed or the knob (41) rotated, the unit alternates between LINEAR SWEEP or LOG SWEEP. Also, the knob toggles between LINEAR SWEEP or LOG SWEEP.
6. **Set up the Function, Amplitude, Offset, and Output.** If sine, triangle, or square waveform is selected, set up the Model 95 the same as described in paragraph 3.5.3.1. The dc function can not be selected in the sweep mode. If variable symmetry waveform is selected, refer to paragraph 3.5.4.1.
7. **Arb waveforms.** If Arb waveforms are selected, setup the same as describe in paragraph 3.5.6.1. Arb waveforms can be swept, only the sample frequency will be swept.
8. **Select Continuous Sweep.** Press the SWEEP MODE (26) key until CONTINUOUS SWEEP is displayed. The unit now continuously sweeps.
9. **Connect the Model 95.** Connect the Model 95 to the receiving device. Use either the BALANCED output (38) or the UNBALANCED output (36) as the sweep output. The SWEEP OUT (29) provides a ramp 0 to +5V (sweep up) or +5 to 0V (sweep down).

3.5.14.2 GPIB Operations

After power on (paragraph 3.5.2), use the following steps to setup the Model 95 for continuous output.

1. **Select the Sweep Mode.** Send the Mode command followed by the sweep parameter.
Mode Commands: MODE or MO
Sweep Parameter: SW or 7.
2. **Select the Start Frequency.** To set up the start frequency send the start frequency command followed by the parameters.
Start Frequency Command: SWEEPSTART or STA
Start Frequency Parameters: Value between 1E-3 and 20E6.
3. **Select the Stop Frequency.** To set up the stop frequency send the stop frequency command followed by the parameters.
Stop Frequency Command: SWEEPSTOP or STO
Stop Frequency Parameters: Value between 1E-3 and 20E6.
3. **Select the Sweep Rate..**Send the sweep time (rate) command and its parameter.
Sweep Time Commands: SWEEPTIME or STL.
Sweep Time Parameters: 100E-3 to 1E2.
4. **Select Linear or Logarithmic Sweep.** Send the Sweep Type command and its parameter..

Sweep Type Command: SWEEPTYPE or STY.
Sweep type Parameter: LINEAR, LI, or 0 for linear sweep.
: LOG, L0, or 1 for logarithmic sweep.

5. **Setup the Function, Amplitude, Offset, and Output.** If sine, triangle, or square waveform is selected, set up the Model 95 the same as described in paragraph 3.5.3.2. The dc function can not be selected in the sweep mode. If variable symmetry waveform is selected, refer to paragraph 3.5.4.2.
6. **Arb Waveform.** If Arb waveforms are selected, setup the same as describe in paragraph 3.5.6.2 . Arb waveforms can be swept, however, only the sample frequency will be swept.
6. **Select Continuous Sweep.** Send the sweep mode command and its parameter.
Sweep Mode Commands: SWEEPMODE or SMD.
Continuous sweep Parameters: C or 2.
7. **Connect the Model 95.** Connect the Model 95 to the receiving device. Use either the BALANCED output (38) or the UNBALANCED output (36) as the sweep output. The SWEEP OUT (29) provides a ramp 0 to +5V (sweep up) or +5 to 0V (sweep down).

Example

The following example uses a GPIB command string to set up the Model 95 for the Continuous Sweep. In this example the output will be a swept 1.5Vpp sine wave from the 50 Ω unbalanced output. The output frequency varies between 1kHz and 10kHz, and swept at a 1 second rate.

`"MODE SW;STA 1E3;STO 1E4 ;STI 1; SMD 2;FU SI; AM 1.5; OP 1; OS U50;EX"`

3.5.15 Triggered Sweep

In the triggered sweep mode, the Model 95, when triggered, produces one sweep beginning at the start frequency and ending at the stop frequency. In general, the setup for triggered sweep is much the same as the continuous sweep mode combined with the triggered mode. As with the triggered mode, the trigger sweep mode can be triggered by an external source, the internal trigger source, the MAN TRIG key, or GPIB commands. In the triggered sweep mode, the Model 95 limits the internally generated trigger frequency to between 0.01 to 10 Hz. Also, if the internal trigger frequency is higher than the sweep time, the Model 95 places the internal trigger frequency less than the sweep time.

3.5.15.1 Local Operation

After power on (paragraph 3.5.2), use the following steps to setup the Model 95 for continuous sweep.

1. **Select the Sweep Mode.** Use the MODE key (22) to step to the sweep mode (SWEEP indicator (23) lit). To step backwards through the modes, press the SHIFT key and then hold down the MODE key. Release the MODE key when the indicator lights to select the mode.
2. **Select the Start Frequency.** Use the SWEEP MODE (26) key to step to the start frequency. When START is displayed, the current start frequency is shown. To change the start frequency, use the keypad (39) or the knob (41), if enabled (ENABLE indicator (40) lit). Use the KNOB key (39) to activate the Knob. The knob increments or decrements the value starting from the flashing digit (Knob key (39)) and automatically enters the new value. When using the keypad, enter values as actual number (5000) or exponential notation (5E3), press the ENTER key to accept the new value.
3. **Select the Stop Frequencies.** Use the SWEEP MODE (26) key to step to stop frequency. When STOP is displayed, the current stop frequency is shown. To change the start frequency, use the keypad (39) or the knob (41), if enabled (ENABLE indicator (40) lit). Use the KNOB key (39) to activate the Knob. The knob increments or decrements the value starting from the flashing digit (Knob key (39)) and automatically enters the new value. When using the keypad, enter values as actual number (5000) or exponential notation (5E3), press the ENTER key to accept the new value.

4. **Select the Sweep Time.** Use the TIME key (28) to select the sweep rate. Sweep rate is the time it takes the Model 95 to sweep between the start and stop frequencies. To change the sweep time, use the keypad (39) or the knob (41), if enabled (ENABLE indicator (40) lit). The knob increments or decrements the value starting from the flashing digit (Knob key (39)) and automatically enters the new value. When using the keypad, enter values as actual number (90) or exponential notation (9E1), press the ENTER key to accept the new value. Sweep time values are between 100ms and 100s. Press SHIFT and Time's UNITS key to shift between frequency and period. After the SHIFT-UNITS key combination the knob may be used to toggle between the units.
5. **Select Linear or Logarithmic Sweep.** Press the SHIFT key (31) and then the LIN/LOG key (28) to select the sweep function. Each time the SHIFT LIN/LOG key combination is pressed or the knob (41) rotated, the unit alternates between LINEAR SWEEP or LOG SWEEP. Also, the knob toggles between LINEAR SWEEP or LOG SWEEP.
6. **Set up the Function, Amplitude, Offset, and Output.** If sine, triangle, or square waveform is selected, set up the Model 95 the same as described in paragraph 3.5.3.1. The dc function can not be selected in the sweep mode. If variable symmetry waveform is selected, refer to paragraph 3.5.4.1.
7. **Arb waveforms.** If Arb waveforms are selected, setup the same as describe in paragraph 3.5.6.1. Arb waveforms can be swept, only the sample frequency will be swept.
8. **Select Triggered Sweep.** Use the SWEEP MODE (26) key until TRIGGERED SWEEP appears.
9. **Select the Internal Trigger.** Use the TRG/LOCK SOURCE key (11) to step to INTERNAL SOURCE.

Set the Trigger Frequency. Use the TRIG FREQ key to display the currently selected internal frequency. Use the knob (41) and the keypad (39) to change the trigger frequency. The knob automatically enters the new trigger frequency. When using the keypad, press the ENTER key to accept the new trigger frequency. Internal trigger frequency range is 10mHz to 10 Hz or 100s to 100 ms. Use the Trigger Frequency's UNITS key (27) to alternate between frequency and period. Press SHIFT and Trigger Frequencies UNITS key to shift between frequency and period. After the SHIFT-UNITS key combination the knob may be used to toggle between the units

10. **Select the External Trigger.** Use the TRG/LOCK SOURCE key (11) to step to EXTERNAL SOURCE.

Connect the External Trigger Source. Connect the external triggering source to the TRIG/FREQ IN connector (12). The EXT indicator (10) is lit. The Model 95 accepts an external signal from dc to 20 MHz either a logic level or bipolar sine wave. The Model 95 triggers on the positive-going edge at the zero-crossing point.

Manual Trigger Use the MAN TRIG key (25) to trigger the generator. When the key is pressed, the Model 95 produces one complete cycle of the selected waveform.

11. **Connect the Model 95.** Connect the Model 95 to the receiving device. Use either the BALANCED output (38) or the UNBALANCED output (36) as the sweep output. The SWEEP OUT (29) provides a ramp 0 to +5V (sweep up) or +5 to 0V (sweep down).

3.5.15.2 GPIB Operation

1. **Select the Sweep Mode.** Send the Mode command followed by the sweep parameter.
 Mode Commands: MODE or MO
 Sweep Parameter: SW or 7.

Connect the External Trigger Source. Connect the external trigger source to the TRIG/FREQ IN connector (12). The Model 95 accepts an external signal from dc to 20 MHz either a logic level or bipolar sine wave. The Model 95 triggers on the positive-going edge at the zero-crossing point.

Triggering with GPIB Commands. To trigger the Model 95 over the GPIB send the following command:

Trigger Command: TRIGGER or TRG.

9. **Connect the Model 95.** Connect the Model 95 to the receiving device. Use either the BALANCED output (38) or the UNBALANCED output (36) as the sweep output. The SWEEP OUT (29) provides a ramp 0 to +5V (sweep up) or +5 to 0V (sweep down).

Example

The following example uses a GPIB command string to set up the Model 95 for the Triggered Sweep. In this example the output will be a swept 1.5Vpp sine wave from the 50 Ω unbalanced output. The output frequency varies between 1kHz and 10 kHz, and swept at a 0.1 second rate. The sweep is triggered internally at a 500 mHz rate.

```
"MODE SW;STA 1E3;STO 1E4 ;STI 1E-1; SMD 3;SRC 0;STF 5E-1;FU SI; AM 1.5; OP 1; OS U50;EX"
```

3.5.16 Manual Sweep

Manual sweep allows the operator to step between the start and stop frequency using the knob or keypad. When using the keypad, the Model 95 only allows values between the the start and stop frequencies to be entered. Also, the Model 95 displays the frequency value closest to the value entered via the keypad. Manual sweep is a local (front panel) operation.

After power on (paragraph 3.5.2), use the following steps to setup the Model 95 for continuous sweep.

1. **Select the Sweep Mode.** Use the MODE key (22) to step to the sweep mode (SWEEP indicator (23) lit). To step backwards through the modes, press the SHIFT key and then hold down the MODE key. Release the MODE key when the indicator lights to select the mode.
2. **Select the Start Frequency.** Use the SWEEP MODE (26) key to step to the start frequency. When START is displayed, the current start frequency is shown. To change the start frequency, use the keypad (39) or the knob (41), if enabled (ENABLE indicator (40) lit). Use the KNOB key (39) to activate the Knob. The knob increments or decrements the value starting from the flashing digit (Knob key (39)) and automatically enters the new value. When using the keypad, enter values as actual number (5000) or exponential notation (5E3), press the ENTER key to accept the new value.
3. **Select the Stop Frequencies.** Use the SWEEP MODE (26) key to step to stop frequency. When STOP is displayed, the current stop frequency is shown. To change the start frequency, use the keypad (39) or the knob (41), if enabled (ENABLE indicator (40) lit). Use the KNOB key (39) to activate the Knob. The knob increments or decrements the value starting from the flashing digit (Knob key (39)) and automatically enters the new value. When using the keypad, enter values as actual number (5000) or exponential notation (5E3), press the ENTER key to accept the new value.
4. **Select Linear or Logarithmic Sweep.** Press the SHIFT key (31) and then the LIN/LOG key (28) to select the sweep function. Each time the SHIFT LIN/LOG key combination is pressed or the knob (41) rotated, the unit alternates between LINEAR SWEEP or LOG SWEEP.
5. **Set up the Function, Amplitude, Offset, and Output.** If sine, triangle, or square waveform is selected, set up the Model 95 the same as described in paragraph 3.5.3.1. The dc function can not be selected in the sweep mode. If variable symmetry waveform is selected, refer to paragraph 3.5.4.1.

6. **Arb waveforms.** If Arb waveforms are selected, setup the same as describe in paragraph 3.5.6.1. Arb waveforms can be swept, only the sample frequency will be swept.
7. **Select Manual Sweep.** Use the SWEEP MODE (26) key until MANSWP is displayed. The manual sweep frequency is displayed.
8. **Connect the Model 95.** Connect the Model 95 to the receiving device. Use either the BALANCED output (38) or the UNBALANCED output (36) as the sweep output. The SWEEP OUT (29) provides a ramp 0 to +5V (sweep up) or +5 to 0V (sweep down).
9. **Manual Sweep.** After Sweep Mode: Manual Sweep is selected, use the keypad (39) or the knob (41), if enabled (ENABLE indicator (40) lit), to change the frequency. The knob increments or decrements the value. When using the keypad, enter values as actual numbers (5000) or exponential notation (5E3), press the ENTER key to accept the new value.

3.5.17 Storing and Recalling Settings

All the operations described in paragraph 3.5 can be stored as a complete setup in the Model 95's memory and recalled for use when needed. Setups can be stored and recalled using both front panel keys and GPIB commands. The Model 95 allows up to 10 stored settings.

3.5.17.1 Local Operation

To Store a Setup,

1. Set up the Model 95 as described in paragraphs 3.5.3 through 3.5.16.
2. Press the STORE key (6) to display the number of the last stored setting. The Model 95 displays the state of the memory: FREE or USED.
3. Use the keypad (39) or knob (41), if enabled (ENABLE indicator (40) lit), to change to another stored setting.
4. Press the ENTER key to store the setup at that location. When ENTER is pressed the Model 95 display flashes DONE and then USED.

To Recall a Setup,

1. Press SHIFT key (31) and then the RECALL key (6) display the number of the last recalled setting. If this is the first recalled setting since power on the number will be lowest number stored.
2. Use the keypad (35) or knob (37), if enabled (ENABLE indicator (36) lit), to change to another stored setting. The Model 95 displays the memory status: FREE or USED.
3. Press the ENTER key to recall the setup. Selecting a FREE location, causes the Model 95 to flash NOSAVE.

3.5.17.2 GPIB Operation

To Store a Setup,

1. Set up the Model 95 as described in paragraphs 3.5.3 through 3.5.16.
2. Send the Store command followed by the Store parameter.
Store Command: STORESETTING or STS.
Store Parameter: 1 to 10.
3. Terminate the command string with an Execute command "EX".

EXAMPLE

To store a setup in setting number 2, send "STS 2; EX".

To Recall a Setup,

1. Send the Recall command followed by the Recall parameter.
Recall Command: RECALLSETTING or RCL.
Store Parameter: 1 to 10.
2. Terminate the command string with an Execute command "EX".

EXAMPLE

To recall a setup in stored setting number 2, send "RCL 2; EX".

3.5.18 Arbitrary Waveforms

This section describes the operation of the Arbitrary waveform generator (Arb). The following topics are contained in this section:

Introduction	paragraph 3.5.18.1
Arb Keys	paragraph 3.5.18.2
Arb Editing	paragraph 3.5.19
Arb-Instrument Setup	paragraph 3.5.19.1
Erasing Arb Waveforms	paragraph 3.5.19.2
Correcting a Mistake	paragraph 3.5.19.3
Point Edit (Local and GPIB)	paragraph 3.5.19.4
Line Edit - Two Point (Local and GPIB)	paragraph 3.5.19.5
Three Point Edit (Local)	paragraph 3.5.19.6
Block Edit	paragraph 3.5.19.7
Storing Arb Waveforms (Local and GPIB)	paragraph 3.5.20
Filter (Local and GPIB)	paragraph 3.5.21
Smoothing (Local and GPIB)	paragraph 3.5.22
Binary Arb Waveform Transfer	paragraph 3.5.23

3.5.18.1 Introduction

The Arbitrary waveform generator allows the user to define their own waveforms. These waveforms can be created using three different editing techniques: point, two-point, and three point. These techniques allow the user to create waveforms from scratch or take existing waveforms stored in memory and modify them. Another type of Arb editing called Block permits defined functions to be placed in an Arb waveform. Block functions placed in a waveform can in turn be edited. The Model 95 allows the user to construct arbitrary waveforms (Arb) which are approximately 8K by 4K (Option 002 expands Arb memory to 32K)s. See figure 3-15. To understand what this means, think of the Model 95 Arb generator as a graph paper which has 8191 points along the horizontal axis - the Model 95 refers to the horizontal points as **Addresses**. The graph's vertical axis contains 2047 points above the center line (+2047) and 2047 points below the center line (-2047) - the Model 95 refers to the vertical points as **Data**. Within this 8K space one large waveform or many smaller waveforms can be constructed. To subdivide the Arb waveform the Model 95 uses the terms **Start Address** and **Stop Address**.

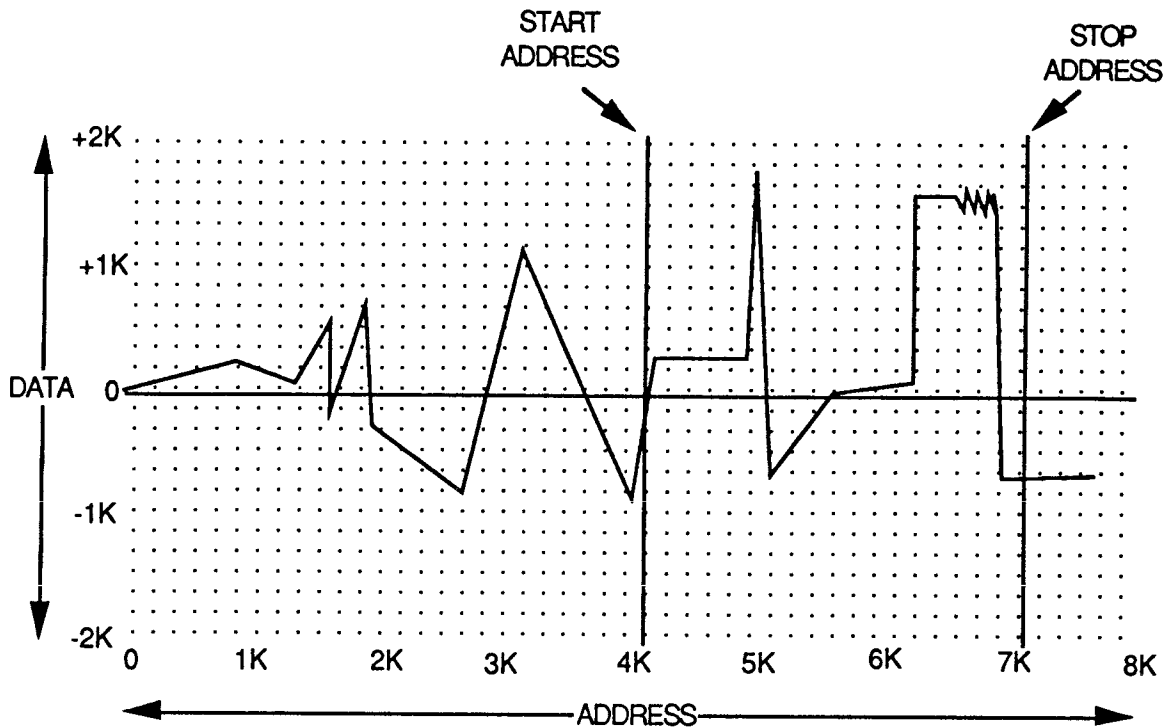

Figure 3-15 Arb Waveforms

The Model 95 uses two forms of Arb memory: Active Memory and Arb Function Memory. The Model 95 uses the active memory as the waveform workspace. The Arb function memory contains those waveforms "stored" by the user. Waveforms in Arb function memory are retained even when power is turned off. When an Arb function is selected the Model 95 automatically copies the waveform from the Arb function memory to the active memory. It is in the active memory where the user can modify the waveform without affecting the waveform in Arb function memory.

3.5.18.2 Arb Keys

The **FREQ/SAMP**, **AMPLITUDE**, and **OFFSET** key function differently for Arb functions than they do for the function generator.

FREQ/SAMP

This keys sets the Arb waveform sample frequency (period) or waveform frequency (period).

Sample Period clocks each point of the Arb waveform; sample period ranges from 1000.0s to 0.00005ms.

Sample Frequency clocks each point of the Arb waveform; sample period ranges from 0.001Hz to 20MHz.

Waveform Period is the repetition rate of a complete cycle of an Arb waveform (Start to Stop Address). The maximum waveform period depends upon the number of points in the waveform:

$$\text{Waveform Period} = \text{Sample Period} \times (\text{Stop Address} - \text{Start Address}).$$

For example, if the waveform consists of 1000 points, the maximum block period will be 0.5ms.

Waveform Frequency is the frequency of a complete cycle of an Arb waveform. The maximum block frequency depends upon the number of points in the waveform:

$$\text{Waveform Frequency} = \text{Sample Frequency} \times (\text{Stop Address} - \text{Start Address}).$$

For example, if the waveform consists of 1000 points, the maximum block frequency will be 20 kHz.

AMPLITUDE

This key sets the amplitude of the Arb waveform. The type of amplitude depends upon the Arb's edit mode.

Amplitude. If Arb is operating in the EDIT OFF mode, the AMPLITUDE key allows the setting of the output amplitude of the entire Arb waveform. However, the actual output voltage may not be the same as set using the AMPLITUDE key because Arb amplitude is dependent on the peak to peak waveform data value.

$$\text{Peak Output Voltage} = (\text{Selected Output Voltage}) (\text{Peak to Peak Waveform Data Value}) / (\text{Maximum Data Value})$$

For example, if the Selected Output Voltage is 10Vpp, the Peak to Peak Waveform Data Value is 2047, and the Maximum Data Value is 4094 then

$$\text{Peak Output Voltage} = (10\text{Vpp}) (2047) / 4094$$

$$\text{Peak Output Voltage} = 5\text{Vpp}.$$

Digital Amplitude (DAMPL). If operating in any of the Arb Edit modes, the AMPLITUDE key allows the setting (scaling in percent) of selected portions of the Arb waveform amplitude. Only the portions between the left and right cursors can be changed by Digital Amplitude. On the scope, the minimum and maximum values of the waveform portion will be highlighted with a cursor. If the knob is used, minimum and maximum markers move up or down to preview the new level. The original peak to peak level of the selected portion waveform is defined as 100%.

OFFSET

This key sets the amplitude of the Arb waveform. The type of offset depends upon the Arb edit mode.

Offset If operating in the EDIT OFF mode, the OFFSET key allows the setting of the offset of the entire Arb waveform. The Model 95 limits the offset to $\text{Offset Vdc} + \text{Amplitude Vp} \leq 7.5\text{Vp}$

Digital Offset (DOFST). If the Arb is operating in any of the Arb Edit modes, the OFFSET key allows the offsetting of selected portions of the Arb waveform. Only the portions between the left and right cursors can be changed by Digital Offset. On the scope, the minimum and maximum points of the waveform portion will be highlighted along with the left and right cursors. If the knob is used, minimum and maximum markers move up or down together to show the new level. The level is measured related to the left cursors position which the Model 95 displays as 00. Digital Offset is displayed a absolute data points relative to the left cursor.. When digital offset is varied, the peak offset level depends on the maximum point of the waveform ($\text{Digital Offset} + \text{Digital Amplitude} \leq 2047$)

3.5.19 Arb Editing

The Model 95 allows three forms of Arb editing to create or modify arbitrary waveforms:

- Point Edit,
- Auto-Line Edit,
- 3-Point Edit.

In addition to these three forms of Arb editing, there is another form called block editing. Block editing allows the user to insert nine different functions within an Arb waveform. Plus block editing allows selected portions of the waveform to be inverted.

Before beginning Arb editing there are several points to discuss: Arb-Instrument setup, erasing Arb waveforms, and correcting mistakes.

3.5.19.1 Arb-Instrument Setup

The best way to edit Arb waveforms requires an oscilloscope with a Z-Axis input. See figure 3-16.

Connect the Model 95's output (Balanced 38 or Unbalance (35)) to Channel 1 of the scope.

Connect the Model 95's SYNC OUT (13) to the scope's External Trigger Input.

Connect the Model 95's Z-Axis Output (C), located on the rear panel, to the scope's Z-Axis Input.

3.5.19.2 Erasing Arb Waveforms

Erasing a Arb Waveform During Editing

Local Operation When editing an Arb waveform, the waveform can be erased (all data goes to 0) without affecting the Arb function memory's waveform by pressing the SHIFT key and then ARB RESET key.

GPIB Operation When editing an Arb waveform, the waveform can be erased (all data goes to 0) without affecting the Arb function memory's waveform by sending the command: ARBRESET or ABR.

Erasing a Stored Arb Waveform

Any stored Arb waveform can be erased. Press the SHIFT key and then the ARB RESET key to initialize the active RAM. The active RAM resets immediately to all zeros at all addresses. To write this into one of the four Arb functions, press SHIFT key and then the ARB STORE key to select one of the four ARB waveform storage locations. Use the knob to scroll through the list: ARB 1, ARB 2, ARB 3, and ARB 4. Press the ENTER key to reset the Arb function. In addition, the cursors reset to the last selected start and stop addresses. In 3 point edit, the Model 95 places a cursor in the middle of the line.

3.5.19.3 Correcting a Mistake

Local Operation Do not worry, if a mistake is made while editing an Arb waveform, the original waveform is still in the Arb function memory. Providing the waveform was not stored using Arb Store or changing the FUNCTION. To access the stored waveform, select UNDO EDIT using the EDIT key.

GPIB Operation When using the Model 95 with a GPIB controller mistakes can also be corrected by using the Arb Edit command and Restore parameter.

Arb Edit Command: ARBEDIT or ABE.

Restore Parameter: RESTORE, R, or 14.

This only works if the waveform with the mistake has not been stored.

3.5.19.4 Point Edit

Point edit technique defines waveforms by modifying a single point at a time. Only the point selected will be changed, other points are not affected. The easiest way to create or edit an Arb waveform is to connect the Model 95 to an oscilloscope; see figure 3-16.

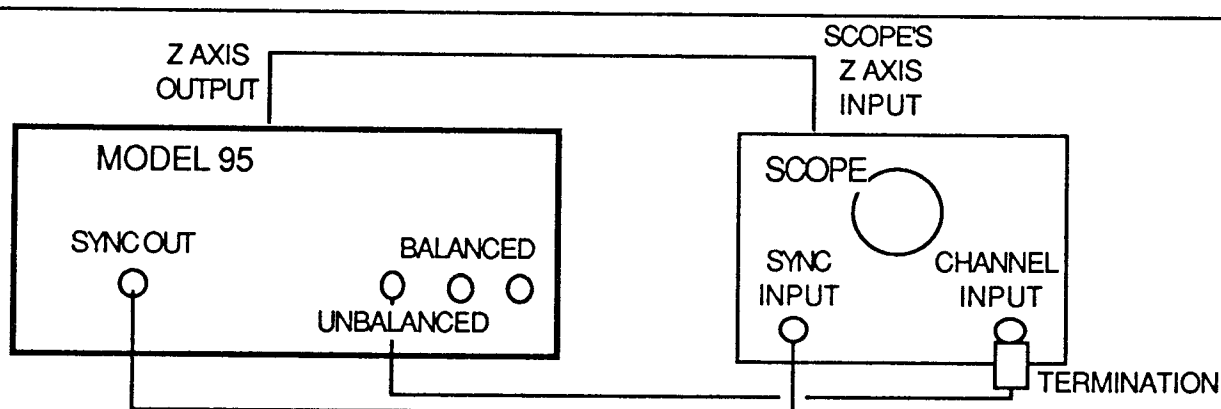

Figure 3-16. Arb Setup.

Figure 3-17 illustrates a point edit waveform. The horizontal line or X axis represents Arb addresses: 0 to 8191 (32767 Option 002), and the vertical line or Y axis represent the Arb data (-2047 to +2047). Remember, only the point selected will be changed.

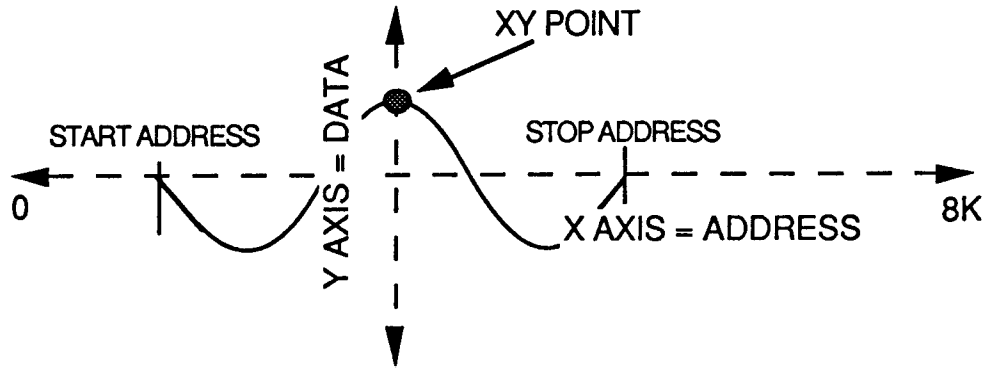
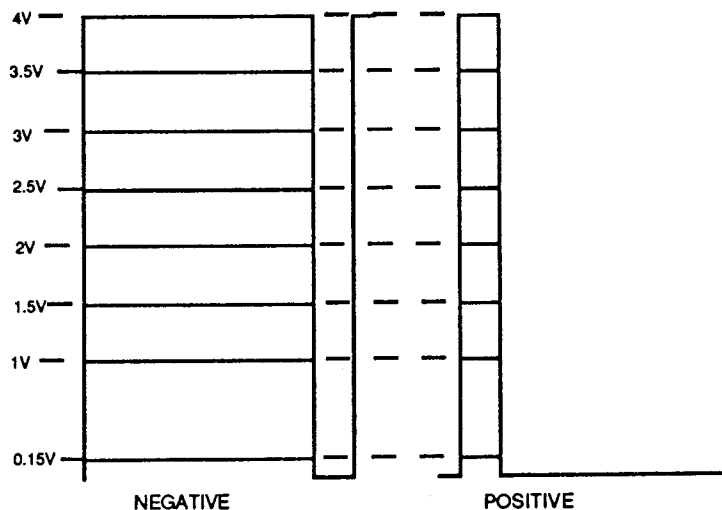

Figure 3-17. Point Edit

Local Operation

After Power On (paragraph 3.5.2), use the following steps to set up Arb waveforms using the point edit method. First, connect the Model 95 and a Scope as illustrated in figure 3-16.

1. **Select Arb Function.** Set up the Model 95 as an Arb generator as described in paragraph 3.5.6.1.
2. **Enter Point Edit.** To select point edit, press the EDIT key (20). The Model 95 always returns to EDIT OFF. Use the EDIT key (20) or knob (41) to change to POINT EDIT. On the scope, the start address and address are highlighted.
3. **Set up the Z Axis Output.** Z axis output makes editing much easier by accenting the cursors. Connect the Model 95's rear panel Z-Axis output (C) to the scope's Z-Axis (intensity modulation) input. Refer to the scope's manual to determine the logic sense and level of the the Z-Axis input. Choose a setup to match the scopes Z-Axis input. Press the Z-AXIS key (3) or use the knob to scroll through the list of positive and negative symmetry pulses outputs from 0.15V to 4V; see below. The output is active when selected



4. **Sync Address.** Press the SYNC ADDR key (14) to display the current Arb sync address. Use the keypad (39) or the knob (41), if enabled (ENABLE indicator (40) lit), to change the sync address. The sync address can be set between 0 and 8191 with the start address being the default. If the sync address must be changed, it can only be placed between the start and stop addresses. Use the KNOB key (39) to activate the Knob. The knob increments or decrements the value starting from the flashing digit (Knob key (39)) and automatically enters the new value. When using the keypad, enter values as actual number (1000) or exponential notation (E3), press the ENTER key to accept the new value. Unless changed, the Sync Address will always be the Start Address.
5. **Entering the Start and Stop Address.** Enter the waveform start address using SHIFT and START ADDRESS (18) keys. Then enter the waveform stop address using SHIFT and STOP ADDRESS (19). The portion of the waveform between the start and stop address will be the waveform used as an Arb function. The Model 95 will not allow the start address to be greater than the stop address and visa versa. The Addresses can be set between 0 and 8191 (32767 Option 002) with the start address being the default. If the sync address must be changed, it can only be placed between the start and stop addresses. Use the KNOB key (39) to activate the Knob. The knob increments or decrements the value starting from the flashing digit (Knob key (39)) and automatically enters the new value. When using the keypad, enter values as actual number (1000) or exponential notation (E 3), press the ENTER key to accept the new value.
6. **Select the Address.** Press the ADDRESS key (18) to display the last selected address. The data for that address is also displayed. A "P" to the left of the address indicates the Model 95 is in point edit. Use the keypad (39) or the knob (41), if enabled (ENABLE indicator (40) lit), to change the address. Use the KNOB key (39) to activate the Knob. The knob increments or decrements the value starting from the flashing digit (knob key (39)) and automatically enters the new value. When using the keypad, enter values as actual number (1000) or exponential notation (1E3).
7. **Enter the Data.** Once the address has been selected, press the DATA key (19) to display the data for that address. Use the keypad (39) or the knob (41), if enabled (ENABLE indicator (40) lit), to change the data. Use the KNOB key (39) to activate the Knob. The knob increments or decrements the value starting from the flashing digit (Knob key (39)) and automatically enters the new value. When using the keypad, enter values as actual number (- 1000) or exponential notation (-1 E 3).

Random Point Edit. If the points are random (not adjacent addresses), press the ADDRESS key (18), and use the keypad or knob to select the address. Press the DATA key (19), and enter the new data using the knob or keypad. Press the ENTER key to accept the new data. Then select another address and enter its new data. Only the points selected will be changed.

Sequential Point Edit. for sequential points (adjacent addresses), press the ADDRESS key, select the address (start at the lowest address in the sequence). Press the DATA key, and enter the new data. Press the DATA key to accept the new data. This key sequence automatically increments to the next Arb address.

GPIB Operation

After instrument setup (paragraph 3.5.1) and power on (paragraph 3.5.2), use the following steps to set up the Model 95 for point edit. The examples show are terminated with a semicolon (;) which indicates the command is part of a string. If only the one command is sent to the Model 95, replace the semicolon with EXECUTE or EX.

1. **Select the Arb Function.** Set up the Model 95 as an Arb generator as described in paragraph 3.5.6.2.
2. **Instrument Setup.** Connect the Model 95 and the Scope as illustrated in figure 3-16.

3. **Select the Point Edit Mode.** To select the Point Edit mode, send the Arb Edit command followed by the Point Edit parameter.
 Arb Edit Command: ARBEDIT or ABE.
 Point Edit Parameter: POINT, P, or 1.
4. **Set the Sync Address.** Send the sync address command followed by its parameter.
 Sync Address Command: SYNCADDRESS or SYN.
 Sync Address Parameter: Send a value between 0 and 8191 (32767 Option 002). The Start Address will be the default sync address. Address can be entered in any format. For example address 1000 can be entered as 1000, 1E3, or 10E3.
5. **Enter the Start Address.** To enter the Start address, send the start address command followed by its parameter.
 Start Address Command: STARTADDRESS or SRA.
 Start Address Parameter: Send a value between 0 and 8190 (32767 Option 002). The start address will be the default sync address. Address can be entered in any format. For example address 1000 can be entered as 1000, 1E3, or 10E3.
6. **Enter the Stop Address.** To enter the Stop Address, send the Stop Address command followed by its parameter.
 Stop Address Command: STOPADDRESS or SPA.
 Start Address Parameter: Send a value between 3 and 8191 (32767 Option 002). Address can be entered in any format. For example address 1000 can be entered as 1000, 1E3, or 10E3.
7. **Select the Address.** To select the address, send the address command followed by its parameter.
 Address Command: ADDRESS or AD.
 Address Parameter: Send a value between 0 and 8191 (32767 Option 002). Address can be entered in any format. For example address 1000 can be entered as 1000, 1E3, or 10E3.
8. **Enter the Data.** To enter the data, send the data command followed by its parameter.
 Data Command: DATA or DA.
 Data Parameter: Send a value between -2047 and +2047. Data can be entered in any format. For example address -150 can be entered as -150 or -1.5E2.
9. **Terminate the command string.** Send the Execute command "EX" to terminate the command string. The Model 95 also accepts the FASTEXECUTE command (FE) which executes the command string significantly faster than the EXECUTE command. However, FASTEXECUTE only works when the frequency, amplitude, offset, or dc offset is changed, and the string is executed without any error checking.

NOTE: The Z-Axis cannot be set up over the GPIB, use the front panel Z-AXIS key (3) to set up Z-Axis.

Random Point Edit. If the points are random (not adjacent addresses), send the address command and its parameter, then the data command and its parameter. Keep sending address/data commands and parameters until finished. Terminate the string with EXECUTE or EX.

Example

The following example uses a GPIB command string to send a random point edit string. This example changes the data at addresses 0 and 10.

```
"MODE C;FU AW3; FR 2E6; AM 1.5;OP 1;OS U50;SYN 0; SRA 0; SPA 10; AD0; DA -5;AD 10; DA5;
EX"
```

Sequential Point Edit. If the points are in a sequence (adjacent addresses), send the address command and its parameter. Then send the data command and its parameter. Send another data command and

parameter; the Model 95 increments to the next higher address. Continue sending data commands and parameter until finished. Terminate the string with EXECUTE or EX.

Example

The following example uses a GPIB command string to send a sequential point edit string.

"MODE C;FU AW3; FR 2E6; AM 1.5;OP 1;OS U50;SYN 0; SPA 0; SPA 10; AD0; DA -5; DA -4; DA -3;DA -2; DA -1;DA 0; DA 1; DA 2; DA 3; DA 4; DA5; EX"

3.5.19.5 Line Edit – 2 Point

Line or two point edit method allows the user to develop waveforms by drawing a line between two points. The locations of the points are defined by addresses (X) and data (Y) entries. See figure 3-18 illustrates a line edit waveform. The horizontal line or X axis represents Arb addresses:0 to 8191 (32767 Option 002), and the vertical line or Y axis represents the Arb data (-2047 to +2047). The line edit method draws a line between the first address data point and the second address data point. The easiest way to create or edit an Arb waveform is to connect the Model 95 to an oscilloscope; see figure 3-16.

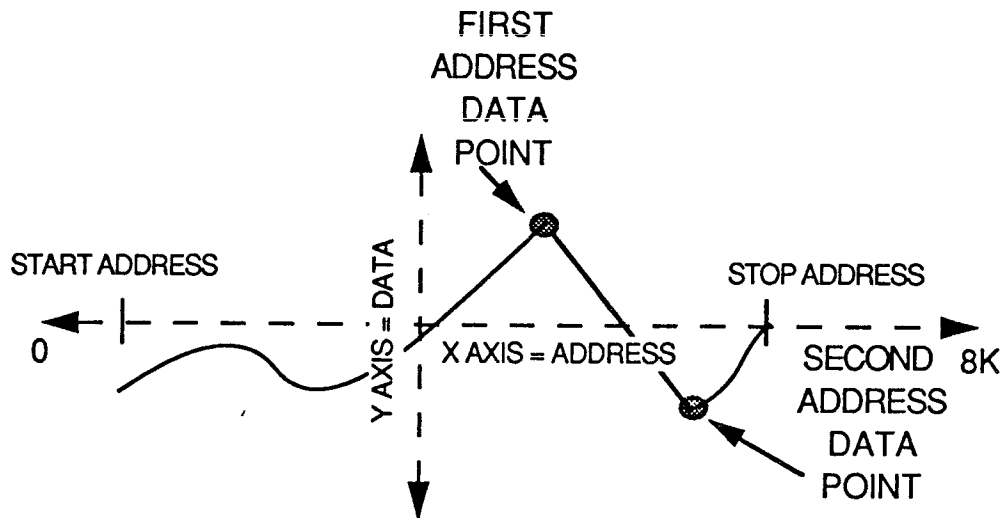

Figure 3-18. Line Edit

Local Operation

After Power On (paragraph 3.5.2), use the following steps to set up Arb waveforms the Model 95 using the line edit method. First, connect the Model 95 and a Scope as illustrated in figure 3-16.

1. **Select Arb Function.** Set up the Model 95 as an Arb generator as described in paragraph 3.5.6.1.
2. **Enter Line Edit.** To select Line Edit, press the EDIT key (20). The Model 95 always returns to EDIT OFF.. Use the EDIT key (20) or knob (41) to change to LINE EDIT (2-PT). The start address and address are highlighted.
2. **Set up the Z Axis Output.** To set up the Z Axis Output refer to paragraph 3.5.19.4, Local Operation, item 3.
3. **Sync Address.** Press the SYNC ADDR key (14) to display sync address. Use the keypad (39) or the knob (41), if enabled (ENABLE indicator (40) lit), to change the sync address. The sync address can be set between 0 and 8191 (32767 Option 002) with the start address being the default. If the sync

address must be changed, it can only be between the start and stop addresses. Use the KNOB key (39) to activate the Knob. The knob increments or decrements the value starting from the flashing digit (Knob key (39)) and automatically enters the new value. When using the keypad, enter values as actual number (1000) or exponential notation (1 E 3), press the ENTER key to accept the new value.

4. **Entering the Start and Stop Address.** Enter the waveform start address using SHIFT and START ADDRESS (18) keys. Then enter the waveform stop address using SHIFT and STOP ADDRESS (19). The portion of the waveform between the start and stop address will be the waveform used as an Arb function. The Model 95 will not allow the start address to be greater than the stop address and visa versa. The Addresses can be set between 0 and 8191 (32767 Option 002) with the start address being the default. Use the KNOB key (39) to activate the Knob. The knob increments or decrements the value starting from the flashing digit (Knob key (39)) and automatically enters the new value. When using the keypad, enter values as actual number (1000) or exponential notation (1E3), press the ENTER key to accept the new value.
5. **Enter the First Address Data Point.** To place the first point, press the ADDRESS key (18), select the address using the knob or keypad. When using the knob to enter the address, the scope displays a highlighted marker to identify the point. If the keypad is used, either the ENTER key or DATA key must be pressed to highlight the point. Press the DATA key (19), enter the new data using the keypad. When in the Line edit mode, the display shows a "L" to the right of the address/data display.
6. **Enter the Second Address Data Point.** To place the second point, press the ADDRESS key (18), select the address using the keypad, press the DATA key (19), enter the new data using the keypad.
7. **Drawing the Line.** The Model 95 draws a line between the first and second address data points when either the ENTER or ADDRESS keys are pressed. All existing data between the two points will be lost.

If the ENTER key is pressed, the Model 95 only draws the line between the two data points.

If the ADDRESS key is pressed, a third point can be placed on the waveform and a line can be drawn between the second and third points. As long as the ENTER key is not pressed lines can be linked throughout the waveform.

GPIB Operation

After instrument setup (paragraph 3.5.1) and power on (paragraph 3.5.2), use the following steps to set up the Model 95 for line or 2-Point edit. The examples shown are terminated with a semicolon (;) which indicates the command is part of a string. If only the one command is sent to the Model 95, replace the semicolon with EXECUTE or EX.

1. **Select the Arb Function.** Set up the Model 95 as an Arb generator as described in paragraph 3.5.6.2.
2. **Instrument Setup.** Connect the Model 95 and the Scope as illustrated in figure 3-16.
3. **Select the Line Edit Mode.** To select the Line Edit mode, send the Arb Edit command followed by the Line Edit parameter.
Arb Edit Command: ARBEDIT or ABE.
Line Edit Parameter: LINE, L, or 2.

4. **Set the Sync Address.** Send the sync address command followed by its parameter.
Sync Address Command: SYNCADDRESS or SYN.
Sync Address Parameter: Send a value between 0 and 8191 (32767 Option 002). The start address will be the default sync address. Address can be entered in any format. For example address 1000 can be entered as 1000, 1E3, or 10E3.
5. **Enter the Start Address.** To enter the Start address, send the start address command followed by its parameter.
Start Address Command: STARTADDRESS or SRA.
Start Address Parameter: Send a value between 0 and 8190 (32767 Option 002). The start address will be the default sync address. Address can be entered in any format. For example address 1000 can be entered as 1000, 1E3, or 10E3.
6. **Enter the Stop Address.** To enter the Stop Address, send the Stop Address command followed by its parameter.
Stop Address Command: STOPADDRESS or SPA.
Start Address Parameter: Send a value between 3 and 8191 (32767 Option 002). Address can be entered in any format. For example address 1000 can be entered as 1000, 1E3, or 10E3.
7. **Entering the First Point.**
Select the Address. To select the address, send the address command followed by its parameter.
Address Command: ADDRESS or AD.
Address Parameter: Send a value between 0 and 8191 (32767 Option 002). Address can be entered in any format. For example address 1000 can be entered as 1000, 1E3, or 10E3.
Enter the Data. To enter the data, send the data command followed by its parameter.
Data Command: DATA or DA.
Data Parameter: Send a value between -2047 and +2047. Data can be entered in any format. For example address -150 can be entered as -150 or -1.5E2.
8. **Entering the Second Point.**
Select the Address. To select the address, send the address command followed by its parameter.
Address Command: ADDRESS or AD.
Address Parameter: Send a value between 0 and 8191 (32767 Option 002). Address can be entered in any format. For example address 1000 can be entered as 1000, 1E3, or 10E3.
Enter the Data. To enter the data, send the data command followed by its parameter.
Data Command: DATA or DA.
Data Parameter: Send a value between -2047 and +2047. Data can be entered in any format. For example address -150 can be entered as -150 or -1.5E2.
9. **Drawing the Line.** Send the Execute command "EX" to terminate the command string. This command draws a line between the first and second points. All data between these points will be lost.
10. **Additional Points.** Repeat steps 7 through 9 until the waveform is completed.
11. **Terminate the command string.** Send the Execute command "EX" to terminate the command string. The Model 95 also accepts the FASTEXECUTE command (FE) which executes the command string significantly faster than the EXECUTE command. However, FASTEXECUTE only works when the

frequency, amplitude, offset, or dc offset is changed, and the string is executed without any error checking.

NOTE: The Z-Axis cannot be set up over the GPIB, use the front panel Z-AXIS key (3) to set up Z-Axis.

3.5.19.6 Three Point Edit

Three point edit allows the user to define waveforms by placing left and right cursors on a "line" and an adjustable point, which can be moved vertically or horizontally, between the cursors. Figure 3-19 illustrates the three point edit method. The horizontal line or X axis represents Arb addresses: 0 to 8191 (32767 Option 002), and the vertical line or Y axis represents the Arb data (-2047 to +2047).

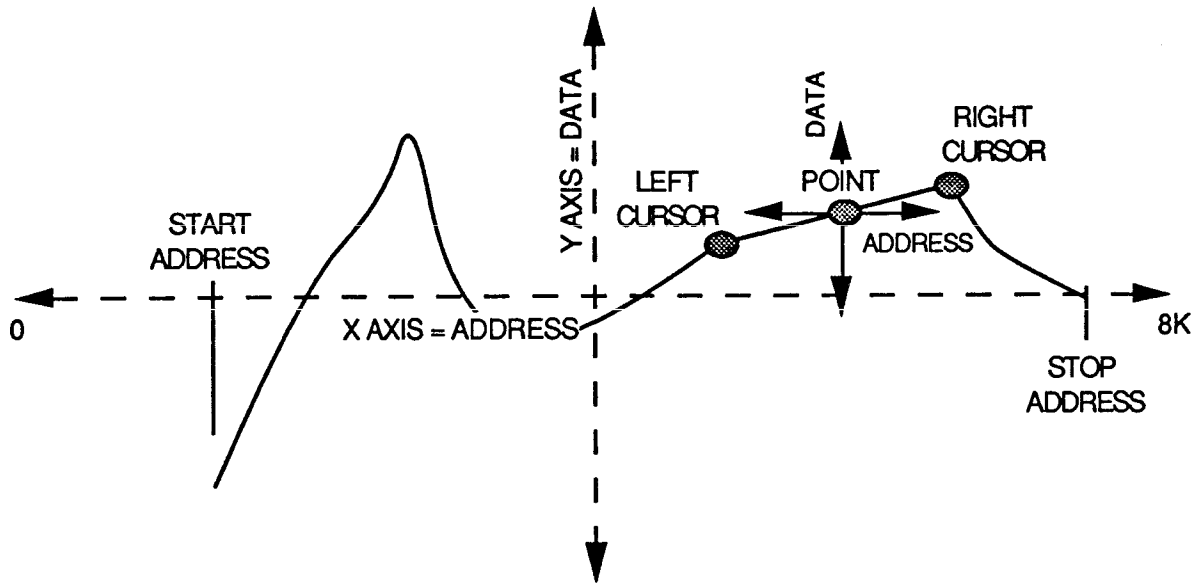

Figure 3-9 Point. 3 Point Edit

Local Operation

After Power On (paragraph 3.5.2), use the following steps to set up Arb waveforms the Model 95 using the three point edit method. The easiest way to create or edit an Arb waveform is to connect the Model 95 to an oscilloscope; see figure 3-16.

1. **Select Arb Function.** Set up the Model 95 as an Arb generator as described in paragraph 3.5.6.1.
2. **Enter Three Point Edit.** To select three point edit, press the EDIT key (20). The Model 95 always returns to EDIT OFF. Use the EDIT key (20) or knob (41) to change to three point edit (LINE EDIT = 3-PT). When the 3 point mode is selected, the start address, left cursor, address, and right cursor are highlighted on the scope.
2. **Set up the Z Axis Output.** See paragraph 3.5.19.4, Local Operation, item 3, Set up the Z Axis Output.
3. **Sync Address.** Press the SYNC ADDR key (14) to display sync address. Use the keypad (39) or the knob (41), if enabled (ENABLE indicator (40) lit), to change the sync address. The sync address can be set between 0 and 8191 with the start address being the default. If the sync address must be changed, it can only be placed between the start and stop addresses. The knob increments or decrements the address starting from the flashing digit (Knob key (39)) and automatically enters

the new address. When using the keypad, enter address as actual number (1000) or exponential notation (1 E 3), press the ENTER key to accept the new address. Unless changed, the Sync Address will always be the Start Address.

4. **Entering the Start and Stop Address.** Enter the waveform start address using SHIFT and START ADDRESS (18) keys. Then enter the waveform stop address using SHIFT and STOP ADDRESS (19). The portion of the waveform between the start and stop address will be the waveform used as an Arb function. The Model 95 will not allow the start address to be greater than the stop address and visa versa. The Addresses can be set between 0 and 8191 (32767 Option 002) with the start address being the default. Use the KNOB key (39) to activate the Knob. The knob increments or decrements the value starting from the flashing digit (Knob key (39)) and automatically enters the new value. When using the keypad, enter values as actual number (1000) or exponential notation (E 3), press the ENTER key to accept the new value.
5. **Place the Left and Right Cursors.** Use the CURSOR key (21) to place the left and right cursors (addresses). Use the knob or keypad to change the cursors. The knob increments or decrements the cursor (address) starting from the flashing digit (Knob key (39)) and automatically cursor's position. When using the keypad, enter values as actual number (1000) or exponential notation (1E 3). Press the ENTER key or CURSOR key to accept the new position. Pressing the CURSOR key (21) steps to the next cursor. The left and right cursors default to the last used settings or start and stop address (Arb Reset). The left and right cursors can not extend beyond the start and stop address.
6. **Moving the Point Horizontally.** Place the point on the line between the left and right cursors using the ADDRESS key (18). Press this key to display the current address, and use the knob or keypad to change the address. Rotating the knob moves the point (highlighted on the scope) left or right (the data value does not change).
7. **Place the Point Vertically.** After selecting the address, press the DATA key (19) to display the current data value. Use the knob or keypad to change the address. Rotating the knob moves the point up or down (the address does not change). A highlighted point shows the new data position.
8. **Drawing the Line.** Press the ENTER key to "draw" a line between the left cursor, address, and right cursor.
9. **Continue the Line.** Repeat steps 5 through 7 until the waveform is complete.

GPIB Operation

The Model 95 does not contain commands and parameters that support the three point edit method.

3.5.19.7 Block Edit

Block edit consists of a group of edit functions that can be performed on specific parts of the Arb waveform. The part of the waveform to be edited is defined by the left and right cursors. The majority of the block edit functions are standard functions which can be inserted between the cursors. The waveform will always be inserted at 100% (± 2047 points) with no offset. Figure 3-20 illustrates the block functions its associated parameters.

Another block edit feature is the waveform invert. Invert allows the portion between the cursors to be inverted. Digital Offset and Digital Amplitude are also block edit features because they affect only a block defined by the left and right cursors.

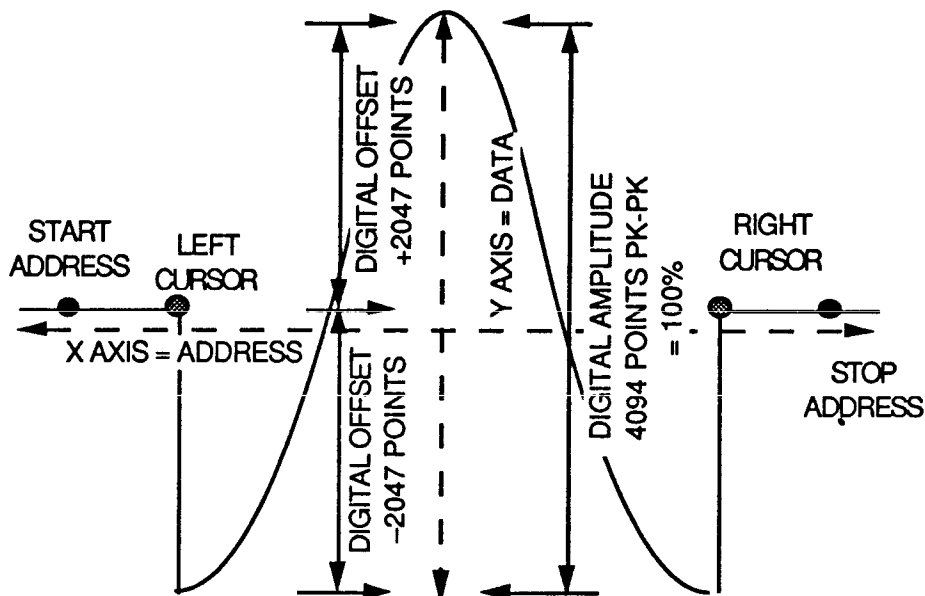

Figure 3-20. Standard Functions

Local Operation

After Power On (paragraph 3.5.2), use the following steps to set up Arb waveforms the Model 95 using the block edit method. The easiest way to create or edit an Arb waveform is to connect the Model 95 to an oscilloscope; see figure 3-16

1. **Select Arb Function.** Set up the Model 95 as an Arb generator as described in paragraph 3.5.6.1.
1. **Set up the Z Axis Output.** To set up the Z-Axis Output refer to paragraph 3.5.19.4, Local Operation, item 3.
2. **Sync Address.** Press the SYNC ADDR key (14) to display the current sync address. Use the keypad (39) or the knob (41), if enabled (ENABLE indicator (40) lit), to change the sync address. The sync address can be set between 0 and 8191 (32767 Option 002) with the start address being the default. If the sync address must be changed, it can only be placed between the start and stop addresses. The knob increments or decrements the address and automatically enters the new address. When using the keypad, enter address as actual number (1000) or exponential notation (1E3), press the ENTER key to accept the new address.
3. **Entering the Start and Stop Address.** Enter the waveform start address using SHIFT and START ADDRESS (18) keys. Then enter the waveform stop address using SHIFT and STOP ADDRESS (19). The portion of the waveform between the start and stop address will be the waveform used as an Arb function. The Model 95 will not allow the start address to be greater than the stop address and visa versa. The Addresses can be set between 0 and 8191 (32767 Option 002) with the start address

- being the default. Use the KNOB key (39) to activate the Knob. The knob increments or decrements the value starting from the flashing digit (Knob key (39)) and automatically enters the new value. When using the keypad, enter values as actual number (1000) or exponential notation (1E3), press the ENTER key to accept the new value.
4. **Place the Left and Right Cursors.** Use the CURSOR key (21) to place the left and right cursors. Cursors actually are Arb addresses. The Model 95 displays the left cursor (address) first, use the knob or keypad to change the address. The knob increments or decrements the cursor (address) and automatically enters the new value. When using the keypad, enter values as actual number (1000) or exponential notation (1E3), press the ENTER key to accept the new value. Again press CURSOR key (21) to step to the right cursor. Use the knob or cursor to enter right cursor (address). The left and right cursors can not extend beyond the start and stop address.
 5. **Enter The Block Functions.** To select block functions, press the EDIT key (20). The Model 95 always returns to EDIT OFF.. Use the EDIT key (20) or knob (41) to change to the block functions. Use the EDIT key (20) or knob (41) to step through the functions: dc, triangle, square, ramp up, ramp down, sine, cosine, inverted sine, and inverted cosine. Once "standard function" has been selected, the ENTER key to place the function between the left and right cursors.
 6. **Adjusting the Amplitude.** To vary the amplitude of the block function, press the AMPLITUDE key (5). Now only the amplitude of the function between the cursors will be adjusted. Digital Amplitude is in percentage of full scale or ± 2047 points. Use the knob or keypad to vary the digital amplitude from 100% to -100%. A negative percent inverts the waveform. Use the KNOB key (39) to activate the Knob. If the Knob is used, the minimum and maximum highlighted markers shows the digital amplitude level. Press ENTER (39) key to change the digital amplitude. If the keypad is used, the digital amplitude changes when the ENTER key is pressed.
 7. **Adjusting the Offset.** To vary the offset of the inserted standard function, press the OFFSET key (7). This allows only offset of the function between the cursors to be adjusted. Instead of an actual value, the offset (Digital Offset) varies ± 2047 points. The function is always inserted at 0 digital offset. Use the knob or keypad to change the digital offset value. Press ENTER (39) key to accept the digital offset; the offset value does not change until the ENTER key is pressed. Once entered, the digital offset can only be decreased, never increased.
 8. **Inverting Portions of the Arb Waveform.** All or part of an Arb waveform can be inverted. To select the portion of the waveform to be inverted, place the left and right cursors; see item 4 in this paragraph. Use the EDIT key (20) to select BLOCK EDIT INVRT. Press the ENTER key to invert the selected portion of the waveform.
 9. **Modifying the Standard Function.** Use the point edit, line edit, or three point edit to modify the standard waveform.

Repeat these steps as need until the desired waveform is created.

GPIB Operation

The Model 95 does not contain commands and parameters that support inserting standard functions.

3.5.20 Storing Arb Waveforms

Once an Arb waveform has been created using they can be stored as Arb functions: ARB1, ARB2, ARB3, or ARB4. Stored Arb waveforms contain the following information:

- Address/Data Points
- Sync Address
- Start Address
- Stop Address
- Left Cursor
- Right Cursor
- Smoothing

Frequency/Sample rate, Amplitude, and Offset must be selected when the Arb waveform is selected as a function; paragraph 3.5.6. The entire setup can be stored as a Stored Setting (paragraph 3.5.17).

Local Operation

There are two methods of storing Arb waveforms: automatically and manually.

The Model 95 automatically stores an Arb waveform when the FUNCTION key is pressed after changing any of the following conditions:

- An edit operation was performed on the waveform,
- The start or stop address was changed,
- The left or right cursor was changed, or
- The waveform was smoothed.

To manually store an Arb waveform, press the SHIFT key and then the ARB STORE key (20) to select one of the four ARB waveform storage locations. Use the knob to scroll through the list: ARB 1, ARB 2, ARB 3, and ARB 4. Press the ENTER key to accept the location. To recall a stored setting, use an Arb as a function (paragraph 3.5.6).

GPIB Operation

As in local operation, there are two methods of storing Arb waveforms: automatically and manually.

The Model 95 automatically stores an Arb waveform when a different function parameter (FUNCTION or FU) is sent after changing any of the following conditions:

- An edit operation was performed on the waveform (ADDRESS, DATA,),
- the start or stop address was changed (STARTADDRESS or STOPADDRESS), or
- The waveform was smoothed (SMOOTHING).

To “manually” store an Arb waveform, send the Arb waveform store command followed by its parameter.

Arb Store Command: ARBSTORE or ABS.

Arb Store Parameter: 1, 2, 3, or 4.

For example: To store an Arb waveform in ARB1, send “ABS 1;”

3.5.21 Filter

Filter enables the Model 95's internal low-pass filters. These filter affect the bandwidth of the the selected Arbitrary waveform. Two filters are selectable: 5MHz bandwidth and 50 kHz bandwidth. Plus no filter selected.

Local Operation

After Power On (paragraph 3.5.2), use the following steps to set up the Arb filter.

1. **Set up the Arb Function.** Set up the Arb function as described in paragraph 3.5.6.1.
2. **Select the Filter Bandwidth.** To select the filter bandwidth, press the FILTER key (17).to display the currently selected filter bandwidth. Use the knob or FILTER key to step through the list:
FILTER NONE,
FILTER 5MHz,
FILTER 50 kHz.

When the desired filter bandwidth is displayed, press the ENTER key (39) to accept the selection.

GPIB Operation

After instrument setup (paragraph 3.5.1) and power on (paragraph 3.5.2), use the following steps to set up the Model 95' filter. The examples shown are terminated with a semicolon (;) which indicates the command is part of a string. If only the one command is sent to the Model 95, replace the semicolon with EXECUTE or EX.

1. **Set up the Arb Function.** Set up the Arb function as described in paragraph 3.5.6.2.
2. **Select the Filter Bandwidth.** To select the filter bandwidth, send the filter command followed by its parameter.
Filter Command: FILTER or FI,
Filter Parameters: 0, 1, or 2.
0 selects 50 kHz bandwidth filter
1 selects 5MHz bandwidth filter
2 selects None - no filter.

For example, to select the 50 kHz bandwidth filter send the command string "FI 0".

3.5.22 Smoothing

Smoothing is the software equivalent of the a simple RC filter with seven selectable bandwidths. Smoothing requires selection of a smoothing constant "N" which the Model 95 also displays as equivalent bandwidth. The equivalent bandwidth depends on the Arb sample rate.

Once an Arb waveform is smoothed, it cannot be unsmoothed. However, if the Arb waveform has not been stored, see paragraph 3.5.19.3, use the EDIT key to select UNDO EDIT which retrieves the unedited waveform.

Local Operation

After Power On (paragraph 3.5.2), use the following steps to set up smoothing.

1. **Set up the Arb Function.** Set up the Arb function as described in paragraph 3.5.6.1.
2. **Select Smoothing Bandwidth.** To select smoothing bandwidth, press the SHIFT key and then the SMOOTH key (17).to display the currently selected smoothing constant and equivalent bandwidth. Use the knob to step through the list:
BW-1 XY HZ
BW-2 XY HZ
BW-3 XY HZ
BW-4 XY HZ

BW5 XY HZ
BW-6 XY HZ
BW-7 XY HZ

Where XY represents the equivalent bandwidth.

When the desired bandwidth is displayed, press the ENTER key (39) to accept the selection. Repeat this process for additional smoothing.

GPIB Operation

After instrument setup (paragraph 3.5.1) and power on (paragraph 3.5.2), use the following steps to set up the Model 95 for Arb smoothing. The examples show are terminated with a semicolon (;) which indicates the command is part of a string. If only the one command is sent to the Model 95, replace the semicolon with EXECUTE or EX.

1. **Set up the Arb Function.** Set up the Arb function as described in paragraph 3.5.6.2.
2. **Select the Smoothing Bandwidth.** To select the smooth bandwidth, send the smooth command followed by its parameter.
Smooth Command: SMOOTH or SM,
Smooth Parameters: 1, 2, 3, 4, 5, 6, or 7..
1 selects XXXX YHz bandwidth,
2 selects XXXX YHz bandwidth,
3 selects XXXX YHz bandwidth,
4 selects XXXX YHz bandwidth,
5 selects XXXX YHz bandwidth,
6 selects XXXX YHz bandwidth,
7 selects XXXX YHz bandwidth.

Where XY represents the equivalent bandwidth.

For example, to select the XXXX YHz bandwidth smoothing send the command string "SM 5".

3.5.23 Binary Arb Waveform Transfer

The Model 95 permits Arb waveforms to be transferred into its active memory via the GPIB in a binary form. To transfer waveforms to the Model 95 in an ASCII format, see paragraph 3.5.18.1 - GPIB Operation. When data is sent in binary form the Model 95 receives data at a --- KByte/s rate. If data were sent in ASCII form over the GPIB, an 8K waveform can take 8 to 10 minutes to load. However, using binary Arb waveform Transfer takes about 8 seconds to load the waveform.

Before Sending the Arb Waveform

Before Transfer the waveform, one of the four Arb waveforms must be selected by sending the command string and parameter:

FUNCTION or FU
ARBWAVEFORM1, AW1, or 4
ARBWAVEFORM2, AW2, or 5
ARBWAVEFORM3, AW3, or 6
ARBWAVEFORM4, AW4, or 7

For example, sending FU AW2 will select Arb waveform 2.

After sending the function command or any other commands, wait for the Model 95 to process the commands in the GPIB input buffer before transferring the Arb waveform. It can take about 300 ms per command to process the last set of commands. If the binary transfer begins before the GPIB buffer is emptied, some data could be lost. To empty the buffer, send a terminator character (typically LF - line feed) and a GET (Group Execute Trigger) before the binary download.

Sending the Data

Sending an ASCII “#” (23₁₆) sets up the Model 95 for binary downloading. After the “#” the data is sent to the Model 95 as two byte binary words in the following order:

XXXXXXXX XXXXXXXX	Beginning Address
XXXXXXXX XXXXXXXX	Word Count (Number of Data Points)
XXXXXXXX XXXXXXXX	Beginning Data Point.
XXXXXXXX XXXXXXXX	Second Data Point
•	
•	
•	
XXXXXXXX XXXXXXXX	Last Data Point

Where XXXX XXXX represents the two byte binary value.

The Model 95 always expects the most significant byte (MSB) to be the first byte sent. Thus if 00000011 00001010 were sent to the Model 95, it receives 00000011 as the MSB.

The beginning address can be between 0 and 8191 (32000 if option 002 is installed). The word count is the number of waveform data points to be entered. The Model 95 accepts up to 8191 (32000 if option 002 is installed).

CAUTION

The beginning address plus the word count must not exceed the total memory: 8191 or 32000 option 002. Otherwise, there could be a loss of waveform data.

The Data Point is a two byte binary word representing a number between 0 and 4095. The actual Y or data value, as described in paragraph 3.5.18, equals Data Point Word value minus 2048. Thus for a 0 Y or data value, 2048 must be entered in the binary value. For example, a data point value of 1000 equals:

$$(1000) - (2048) = -1048$$

CAUTION

If the number of data points exceeds the word count, the Model 95 interprets the extra data points as ASCII value. If one of these ASCII values represents a legal Model 95, it could cause adverse affects on the unit's operation.

CAUTION

The Model 95 expects only the correct number of data points as defined by the word count.

If too many data points are sent to the Model 95, it assumes the extra data points are ASCII characters and tries to interrupt them. If some of these interrupted characters are Model 95 commands, the interrupted characters could cause operating errors.

When too few data points are sent to the Model 95, it assumes the remaining bytes are binary data points. If ASCII characters are sent when the Model 95 expects binary data points, the Model 95 interpret the ASCII characters as binary values. This means the ASCII commands are lost and the Arb waveform contain errors. The Model 95 will wait for 500 ms after receiving the last binary data point and then be ready for ASCII characters.

Example

Use the following example to produce a stair step Arb waveform. In this example the beginning address is 10 and the word count is 25. The Arb function used will be ARB1 in this example. For more examples on Binary Transfer, refer to Wavetek's *Arbitrary Waveform Cookbook, Volume 2*.

Select the Arb Function. Send the Arb1 command and parameter to select the Arb 1 function.

Send the function command FUNCTION or FU.

Send the Arb 1 parameter: ARBWAVEFORM1, AW1, 4.

Send the Binary Transfer

Send Binary Transfer ASCII character "#". This places the Model 95 in the Binary Transfer Mode.

Send the Beginning or Start Address (two byte Binary value, MSB first) – 10 in this example:

00000000 00001010

Send the Word Count (two byte Binary value, MSB first) – 25 in this example:

00000000 00011001

Send the Binary data points (two byte Binary value, MSB first). This example starts at a value of 2048 (0 on the Model 95's Arb waveform) and increments each step by a value of 80.

```
00001000 00000000
00001000 01010000
00001000 10100000
00001000 11110000
00001001 01000000
00001001 10010000
00001001 11100000
00001010 00100000
00001010 01110000
00001010 11000000
00001011 00010000
00001011 01100000
00001011 10110000
00001100 00000000
00001100 01010000
00001100 10100000
00001100 11010000
00001101 00100000
00001101 01110000
00001101 11000000
00001110 00010000
00001110 01100000
00001110 10110000
00001111 00000000
00001111 01010000
```

Storing the Arb Waveform. After completing Binary Transfer, the waveform should be stored in Arb memory before it is lost or damaged. Model 95 provides two ways of storing the waveform: changing the function and using Arb Store command.

To store the Arb waveform by changing the function, simply select another function. When a different function is selected the Model 95 automatically stores the waveform in active memory in the ARB function selected (ARB1 in this example). For this example select the sine function:

Send the function command: FUNCTION or FU.
Send the Sine parameter: SINE, SI, or 0.

Also the ARBSTORE command will store the waveform in Arb memory. Using the Arb Store command allows the operator to place the waveform in any of the four Arb function memory. For example, to place the waveform in ARB2, send the following command and parameter:

Send the Arb Store command: ARBSTORE or ABS
Send the Arb Store parameter: 4 (ARB4)
"ABS 4".

CAUTION

Some computer drivers will send the binary byte in reverse order (LSB MSB). Therefore, the bytes must be reversed (MSB LSB) before sending them to the Model 95. Appendix B provides a "QuickBASIC" program that will reverse the bytes.

APPENDIX B

BYTE REVERSING

The following program in QuickBASIC will break down the integer value into two bytes, and then recombine them in reverse order to be accepted in the Model 95 integer format (MSB LSB).

```
DEFINT A-Z
DIM UpperByte, LowerByte AS STRING * 1

LET N = InputValue%

IF N >= 0 THEN
    UpperByte$ = CHR$(INT(N/256))
    LowerByte$ = CHR$(N AND 255)
ELSE
    UpperByte$ = CHR$(255 - ABS(N+1)\256)
    LowerByte$ = CHR$(255 - ABS(N) MOD 256)
END IF

RevInteger$ = UpperByte$ + LowerByte$

END FUNCTION

(CREATE "#AADD" header string for DMA transfer where:
#      Literal character (1 Byte: ASCII 23)
AA     Start or Beginning Address (2 Bytes: Upper Lower)
DD     Data Points (2 Bytes: Upper Lower)

Header$ = "#" + RevInteger$(StartAddress%) + RevInteger$(WordCount%)

FOR X = 0 TO WordCount%
    Arb1$ = Arb1$ + RevInteger$(Waveform%(X))
NEXT X
Arb$$ = Header$ + Arb$
CALL IBWRT (ARBGPB%, ArbString$)
```

